



KEGEL

YOUR LANES | OUR PASSION



*Products
&
Parts*

2015-16



Welcome to the FLEX Generation

The modern design of the FLEX makes a bold statement, and the DUO conditioning system under the lid backs it up. DUO Technology gives you the benefit of easily using more than one lane conditioner in your center. By combining the precise accuracy of Sanction Technology™ with dual conditioner cartridges, and still being able to verify how much conditioner will be applied to the lane, DUO Technology gives you versatility, dependability, and accountability.

FLEX gives you features to improve performance, simplify your experience, and allows you to have more control of your lane maintenance program. Want even more? Choose from four colors and add on any of our factory upgrades for a machine perfectly customized to fit your needs.



RED



BLACK



WHITE



BLUE

FLEX	17-5701 (115V/60 Hz)	17-5703 (115V/60 Hz)	17-5705 (115V/60 Hz)	17-5707 (115V/60 Hz)
	17-5751 (230V/50 Hz)	17-5753 (230V/50 Hz)	17-5755 (230V/50 Hz)	17-5757 (230V/50 Hz)
FLEX WALKER	17-5801 (115V/60 Hz)	17-5803 (115V/60 Hz)	17-5805 (115V/60 Hz)	17-5807 (115V/60 Hz)
	17-5851 (230V/50 Hz)	17-5853 (230V/50 Hz)	17-5855 (230V/50 Hz)	17-5857 (230V/50 Hz)

FLEX Machine Weight: 331 lbs. | 150.1 kg

FLEX Walker Machine Weight: 370 lbs. | 167.8 kg

CONDITIONING

- Uses Sanction Technology™ to measure conditioner volume before applying to lane
- Variable Speed Buffer option (see upgrades)
- DUO conditioning system (two pumps and two conditioner cartridges)
- DUO transfer system
- Two pre-filled/refillable conditioner cartridges
- Alternate two conditioners in one pass
- Adjustable microliter streams (per load setting)
- Ability to condition each lane in less than 90 seconds
- Conditioner float switches with low level warning message
- Board-to-board pattern control
- "Oil Only" function
- Touchscreen control of oil pump calibration

CLEANING

- Cleaner Mixing System option (see upgrades)
- Squeegee cartridge for easy replacement of blades
- Sprayless cleaning system
- Ability to monitor and adjust cleaner output
- Cleaner float switches with low level warning message
- Large waste recovery tank (50+ lanes before emptying)
- Duster/cleaning cloth waste roll on top for easy removal
- Patented cushion roller wrap for better cleaning
- Super quiet DC vacuum motor
- "Clean Only" function
- "Dust Only" function
- Touchscreen control of cleaner pump calibration

DRIVE

- Patented six variable drive speeds
- Independent adjustable cleaning speed
- Self-adjusting drive speeds
- LED arrow for better operator positioning
- Dual Drive System

TOUCHSCREEN/PLC

- Full color 5" touchscreen display
- Three programs for both AM and PM
- Stores 30 programs in memory
- Test input/output menu option
- Full detailed error messages with help screens

BATTERIES

- Single lightweight lithium battery
- Three battery options based on number of lanes conditioned per day
- External battery charger

SPECIAL FEATURES

- Pin Deck treatment spray system ^{NEW!}
- Easy sliding detachable lid assembly ^{NEW!}
- KOSI™ software kit included (Kegel Online Support Interface)

WALKER ONLY FEATURES

- Zero Turn Radius lane to lane walking function
- Auto-aligning lane whiskers
- Smart processor auto-align memory
- Object detection
- Automatic burn pair



FLEX BONUS WARRANTY

Receive an 18 month warranty with an additional 18 months if you agree to only use Kegel lane maintenance products in your lane machine.

UPGRADES

Cleaner Mixing System* • Self-mixing cleaner adjustments
• Precise mixing ratios

Variable Speed Buffer* • Ability to customize four preset buffer speeds
• More control of front to back taper

Batteries • Each machine comes with our K2 Energy® lithium battery
• Upgrade to larger battery based on number of lanes conditioned per day



158-1634**
(40 lanes)



158-1634B
(62 lanes)



158-1634C
(90 lanes)

* Factory upgrade (must be installed at time of purchase).

** All FLEX Machines come standard with battery 158-1634.





Cut the Cord



Innovation is the Key



Affordable Quality



The Kustodian ION is battery powered so you don't need to hassle with the cord during use. While it cleans and conditions the lane, you have more time to do other things.

Features:

- All of the Kustodian Plus features
- Battery powered for hassle-free operation
- Two dry-cell batteries can last up to 32 lanes per charge
- Upgradeable to single lightweight lithium battery

Machine Weight: 362 lbs. | 164.2 kg

Part Number:

17-5400 (115V/60 Hz) MODEL B

17-5450 (230V/50 Hz) MODEL B

Lane Machine Assist

One person can quickly and easily raise and lower their lane machine safely.



Physical Properties:

- Color: Black
- Dimensions: Width: 60" | Height: 8" | Depth: 8"
- Lifting Capacity: Any Kegel Lane Machine
- Packaging: Assembled and ready to mount

Part Number: 154-8510

(Must be installed by a qualified contractor.)

Bracket Kit for FLEX models Part Number: 158-8615



KUSTODIAN BONUS WARRANTY

Receive a 12 month warranty with an additional 24 months on select items if you agree to only use Kegel lane maintenance products in your lane machine.

The Kustodian PLUS sets a high benchmark for the Kustodian family of lane machines. It's equipped with patented Sanction Technology™, a fluid metering conditioning system that gives you the ability to measure the exact volume of oil "before" you condition your lanes. Plus, the cleaning system features a patented sprayless system delivering the industry's cleanest lanes.

Features:

- Patented Transfer Brush Conditioner System provides consistency with little maintenance
- Patented Cushion Roller Wrap increases footprint on the lane to enhance cleaning performance

The Crossfire is a compact, durable and highly functional lane machine at a very affordable price. This wick combination lane machine allows small centers to experience high quality lane maintenance only Kegel can deliver.

Features:

- Cleans and conditions the lane in about 80 seconds
- On-board keypad for simple machine programming
- 6 High-Flow Wick Pads (upgradeable to 8)
- 12 Lane Conditioner Capacity (upgradeable to 60)
- 32 Lane Cleaner Capacity
- 3 Drive Speeds for enhanced pattern taper
- Compact Design

- Clean and Condition the lane in less than 90 seconds
- Condition only, clean only, and simultaneous modes
- 6 Drive Speeds for smooth lengthwise taper
- Large recovery tank can hold 50+ lanes of waste before emptying
- Cleaning cloth waste roll is located on top for easy removal
- KOSI™ Software is included to make pattern adjustments easy

Machine Weight: 310 lbs. | 141 kg

Part Number:

17-5100 (115V/60 Hz) MODEL B

17-5150 (230V/50 Hz) MODEL B

Machine Weight: 275 lbs. | 124.7 kg

Part Number:

Crossfire - 6 PAD MODEL C

17-5200C (115V/60 Hz) 6 PAD/CAM MACHINE

17-5250C (230V/50 Hz) 6 PAD/CAM MACHINE

Optional Upgrade Kit

Increase to 8 Wick Pads and Conditioner Capacity to 60 lanes

158-8241 - CROSSFIRE UPGRADE KIT - 115V

158-8241E - CROSSFIRE UPGRADE KIT - 230V

LANE MACHINE COMPARISON CHART

	FLEX WALKER	FLEX	ION	KPLUS
CONDITIONING				
Sanction Technology™ fluid metering conditioning system	✓	✗	✗	✗
Conditions each lane in less than 90 seconds	✓	✗	✗	✗
Conditioner float switches with low level warning message	✓	✗	✗	✗
Left-Right pattern control	✓	✗	✗	✗
"Oil Only" function	✓	✗	✗	✗
Touchscreen control of microliter stream	✓	✗		
Touchscreen control of oil pump calibration	✓	✗		
DUO conditioning system (two pumps and two conditioner cartridges)	✓	✗		
DUO transfer system (roller and single transfer brush)	✓	✗		
Two pre-filled/refillable conditioner cartridges	✓	✗		
Ability to alternate two conditioners in one pass	✓	✗		
Board-to-board pattern control	✓	✗	✗	✗
Measure conditioner volume before applying to lane	✓	✗	✗	✗
Adjustable mic streams (per load setting)	✓	✗		
Different conditioners in each cartridge	✓			
4 Variable Buffer speeds	OPTIONAL	OPTIONAL		
CLEANING				
Sprayless cleaning system	✓	✗	✗	✗
Ability to monitor and adjust cleaner output to the milliliter	✓	✗	✗	✗
Cleaner float switches with low level warning message	✓	✗	✗	✗
Large waste recovery tank (50+ lanes before emptying)	✓	✗	✗	✗
Duster/Cleaning cloth waste roll on top for easy removal	✓	✗	✗	✗
Patented cushion roller wrap for better cleaning	✓	✗	✗	✗
Ultra quiet DC vacuum motor	✓	✗	✗	
"Clean Only" function	✓	✗	✗	✗
"Dust Only" function	✓	✗	✗	✗
Adjustable "End Cleaning" and "Return" distance	✓	✗	✗	✗
Multi-adjustment squeegee assembly	✓	✗	✗	✗
Touchscreen control of cleaner volume	✓	✗		
Squeegee cartridge for easy replacement of blades	✓	✗		
Touchscreen control of cleaner pump calibration	✓	✗		
Redesigned cleaner supply tank with bigger opening for filling	✓	✗		
New style recovery tank with handles for better transporting/emptying	✓	✗		
Self-mixing cleaner system	OPTIONAL	OPTIONAL		
DRIVE				
Patented six variable drive speeds	✓	✗	✗	✗
Independent adjustable cleaning speed	✓	✗		
Self-adjusting drive speeds	✓	✗		
Zero Turn Radius lane to lane walking function	✓			
Auto-aligning lane whiskers	✓			
Smart processor auto-align memory	✓			
Object detection	✓			
LED arrow for better operator positioning	✓	✗		
KEYPAD/PLC				
Standard 2-line display keypad			✗	✗
Full Color 5" touchscreen display	✓	✗		
One program for AM and PM			✗	✗
Three programs for AM and PM	✓	✗		
Automatic burn pair	✓	✗		
Stores 4 programs in memory			✗	✗
Stores 30 programs in memory	✓	✗		
Test output menu option			✗	✗
Test input/output menu option	✓	✗		
Coded error messages			✗	✗
Full detailed error messages with help screens	✓	✗		
BATTERIES				
On-board charger			✗	
Single lightweight lithium battery	✓	✗	OPTIONAL	
External battery charger	✓	✗		
2 Dry-cell 925 batteries (approx. up to 32 lanes per charge)			✗	
3 lithium battery options based on number of lanes conditioned per day	✓	✗		
SPECIAL FEATURES				
KOSI™ software kit included (Kegel Online Support Interface)	✓	✗	✗	✗
Pin Deck treatment spray system	✓	✗		

Lane Conditioners

NEW!



CURVE
LANE CONDITIONER



Stay Ahead of the Curve

At Kegel we are always looking to extend the boundaries of performance, yet we don't want to overlook our current customers. With that in mind, we have developed Curve, a lane conditioner that advances the capabilities of all our existing six thousand Sanction Technology™ Lane Machine owners worldwide.

Curve, Kegel's newest lane conditioner, has been designed to extend our line of performance products and give you more

hook when you want it. With Kegel's new custom G3 additive, Curve delivers consistent ball motion frame after frame and has provides more predictable game three ball reaction. It is pinsetter friendly, has low carry-down characteristics, and cleans easily...making it the perfect solution for your bowling center.

For Sanction Technology™ Lane Machines

- Viscosity: 41.0 cps.
- Surface Tension: 22.0 dyn/cm

Part Number: 156-8145

- Shipping Weight: 40 lbs.
- Packaging: 1.25 gallon containers
- 4 containers per case = 5 gallons



Part Number: 156-8145C

- Shipping Weight: 38.5 lbs.
- Packaging: 1.5 liter cartridges
- 12 cartridges per case = 4.75 gallons



FIRE[™]

For more hook or slick lane surfaces

For Sanction Technology™ Lane Machines

- Viscosity: 45.1 cps.
- Surface Tension: 23.6 dyn/cm

Part Number: 156-8135

- Shipping Weight: 40 lbs.
- Packaging: 1.25 gallon containers
- 4 containers per case = 5 gallons



Part Number: 156-8135C

- Shipping Weight: 38.5 lbs.
- Packaging: 1.5 liter cartridges
- 12 cartridges per case = 4.75 gallons



ICE[™]

For more hold area or high friction lane surfaces

For Sanction Technology™ Lane Machines

- Viscosity: 40.9 cps.
- Surface Tension: 23.2 dyn/cm

Part Number: 156-8130

- Shipping Weight: 40 lbs.
- Packaging: 1.25 gallon containers
- 4 containers per case = 5 gallons



Part Number: 156-8130C

- Shipping Weight: 38.5 lbs.
- Packaging: 1.5 liter cartridges
- 12 cartridges per case = 4.75 gallons

Lane Conditioners

WICK-PAD CONDITIONER



Physical Properties:

- Viscosity: 24.1 cps.
- Surface Tension: 23.6 dyn/cm.
- Shipping Weight: 40 lbs.
- Packaging: 1.25 gallon containers for easy use (4 containers per case = 5 gallons)

Part Number: 156-8105

WICK-PAD & SANCTION® CONDITIONERS



Physical Properties:

- Viscosity: 31.2 cps.
- Surface Tension: 23.7 dyn/cm.
- Shipping Weight: 40 lbs.
- Packaging: 1.25 gallon containers for easy use (4 containers per case = 5 gallons)

Part Number: 156-8095



Physical Properties:

- Viscosity: 31.3 cps.
- Surface Tension: 23.5 dyn/cm.
- Shipping Weight: 40 lbs.
- Packaging: 1.25 gallon containers for easy use (4 containers per case = 5 gallons)

Part Number: 156-8125

SANCTION® CONDITIONERS



Physical Properties:

- Viscosity: 36.5 cps.
- Surface Tension: 23.1 dyn/cm.
- Shipping Weight: 40 lbs.
- Packaging: 1.25 gallon containers for easy use (4 containers per case = 5 gallons)

Part Number: 156-8115



Physical Properties:

- Viscosity: 47.3 cps.
- Surface Tension: 22.7 dyn/cm.
- Shipping Weight: 40 lbs.
- Packaging: 1.25 gallon containers for easy use (4 containers per case = 5 gallons)

Part Number: 156-8025



Physical Properties:

- Viscosity: 50.3 cps.
- Surface Tension: 23.9 dyn/cm.
- Shipping Weight: 40 lbs.
- Packaging: 1.25 gallon containers for easy use (4 containers per case = 5 gallons)

Part Number: 156-8075

Conditioner Comparison

SANCTION TECHNOLOGY™								
PROPERTIES	CURVE	FIRE	ICE	NAVIGATE	INFINITY	PRODIGY	DEFENSE-S	OFFENSE HV
VISCOSITY (at 72.5 °F / 22.8 °C)	41	45.1	40.9	31.3	36.5	31.2	47.3	50.3
DURABILITY								
High League Lineage	7	8	10	8	8	6	9	5
High Open Play Lineage	10	10	8	7	6	8	6	8
Reduced Pinsetter Calls	10	9	9	8	7	8	6	8
Easy Cleaning	10	10	10	7	5	7	5	9
Limits Carry Down	10	8	8	8	7	8	7	5
LANE SURFACES								
Pro Lane™	10	10	9	8	5	9	6	5
Anvilane™	8	9	10	7	9	7	7	7
AMF HPL™	9	9	10	7	8	7	8	7
AMF SPL™	8	8	10	8	9	7	7	8
Laneshield®	7	6	8	7	7	7	7	10
Guardian®	8	8	10	7	7	7	8	6
MAD Lanes®	9	9	10	9	9	7	7	7
WOOD FINISHES								
Water Base	8	8	10	5	7	5	9	5
100% Solids	8	8	10	4	7	5	9	7

WICK-PAD TECHNOLOGY			
PROPERTIES	NAVIGATE	PRODIGY	CROSSFIRE
VISCOSITY (at 72.5 °F / 22.8 °C)	31.3	31.2	24.1
WICKING TIME	13 minutes	14 minutes	10 minutes
DURABILITY			
High League Lineage	9	5	7
High Open Play Lineage	8	8	6
Reduced Pinsetter Calls	8	9	6
Easy Cleaning	7	7	8
Limits Carry Down	8	8	9
LANE SURFACES			
Pro Lane™	10	9	8
Anvilane™	8	8	10
AMF HPL™	8	8	8
AMF SPL™	5	6	8
Laneshield®	8	8	10
Guardian®	7	5	7
MAD Lanes®	5	7	9
WOOD FINISHES			
Water Base	4	5	9
100% Solids	4	5	9

Lane Cleaners



DEFENSE CX4 S

Physical Properties:

- Designed for low friction surfaces and stronger backend reaction
- pH: 11.5
- Shipping Weight: Only 10 lbs.
- Packaging: 3.29 liters (1 US Gallon)

Part Number: 156-8435



DEFENSE CX4

Physical Properties:

- Designed for high friction surfaces
- pH: 12.8
- Shipping Weight: Only 13 lbs.

Part Number: 156-8425



FIZZION
CONCENTRATED CLEANER

Physical Properties:

- pH: 7.8
- Appearance: White Tablet with Citrus Scent
- Tablet Weight: 42 g
- Shipping Weight: 12 lbs. per case (4 bags/case)
- Packaging: 24 tablets/bag (4 bags/case = 96 tablets total)

Part Number: 156-8500B



DEFENSE-C

Physical Properties:

- pH: 12.6
- Shipping Weight: 46 lbs.
- Packaging: 2.5 gallon containers (2 containers per case = 5 gallons)

Part Number: 156-8405

Note: All Kegel cleaners meet European compliance requirements.

Other Supplies

K2 SELECT
EZ CORE TECHNOLOGY



EZ Core Technology makes changing cloth "Quick & EZ"! Stop handling dirty cloth and get ultimate cleaning results.

Physical Properties:

- Color: White
- Roll Dimensions: 43" wide x 60' long
- Shipping Weight: Under 12 lbs.
- Packaging: 4 rolls per case

Part Number:

K2 Select (Reusable PVC Core): 153-0047EZ

K2 Kloth (Cardboard Core): 153-0047P

Center Care Products



Spot On Pin Deck Spray ^{NEW!}

Spot On Pin Deck Spray is the only product that can be used manually or inserted directly in your lane machine* for simple application with the push of a button!

Spot On creates a film to prevent pins from sliding which helps improve pin carry and eliminates off-spot pins and out-of-ranges. This ready-to-use spray comes in a 14 oz. bag-on valve can – no dilution necessary. Cleans easily and doesn't attract dirt to your pin deck!

* Designed for use with the 2016 FLEX Lane Machine.

Part Number: 156-8310 - Case (4 - 14 oz. cans)



Balance Approach All-In-One ^{NEW!}

Balance is the all-in-one solution to maximize the performance of your synthetic approaches. With one product you can create an even and uniform surface for optimal slide conditions. Clean and condition your approaches in one simple application. Use with a rotary buffer.

Part Number: 156-8320 - Case (4 - 16 oz. bottles)



Buffing Pads ^{NEW!}



Buffing Pad (White)

This 21" buffing pad is made with absorbent synthetic blended yarn. Gently clean away dust from less textured approaches. Machine-washable.

Part Number: 159-4511



Buffing Pad (Green & White)

With green scrubbing stripes on both sides, this 21" buffing pad offers a little something extra. Perfect for more textured lane surfaces, this buffing pad allows you to gently loosen and remove dirt build-up from the pores of your approach. Machine-washable.

Part Number: 159-4510

Microfiber Approach and Utility Mops ^{NEW!}

Color-coded to separate your approach mops from other mops used in less sensitive areas of your center. These high performance microfiber mops grab dirt and dust for quick and easy cleaning. Approach Mop ideal for synthetic approaches. Utility Mop perfect for cleaning in the pit, bowlers area, and elsewhere throughout your center. Machine-washable.



Approach Mop (Green)

- 36" Approach Mop only (Green) - 159-4402
- 36" Approach Mop with Handle Assembly - 159-4402C
- 48" Approach Mop only (Green) - 159-4403
- 48" Approach Mop with Handle Assembly - 159-4403C



Approach Mop (White)

- 24" Approach Mop only (White) - 159-4420
- 24" Approach Mop with Handle Assembly - 159-4420C
- 36" Approach Mop only (White) - 159-4421
- 36" Approach Mop with Handle Assembly - 159-4421C
- 48" Approach Mop only (White) - 159-4422
- 48" Approach Mop with Handle Assembly - 159-4422C



Utility Mop (Blue)

- 18" Pit Mop only (Blue) - 159-4410
- 18" Pit Mop with Handle Assembly - 159-4410C
- 24" Pit Mop only (Blue) - 159-4411
- 24" Pit Mop with Handle Assembly - 159-4411C
- 36" Pit Mop only (Blue) - 159-4412
- 36" Pit Mop with Handle Assembly - 159-4412C

Industrial Approach Mop ^{NEW!}

This industrial white approach mop is made of durable non-looped cotton strands that easily lift away dirt and dust. Recommended for wood approaches. Machine-washable.



- 24" Approach Mop only (White) - 159-4430
- 24" Approach Mop with Handle Assembly - 159-4430C
- 36" Approach Mop only (White) - 159-4431
- 36" Approach Mop with Handle Assembly - 159-4431C
- 48" Approach Mop only (White) - 159-4432
- 48" Approach Mop with Handle Assembly - 159-4432C

Gutter Mop ^{NEW!}



This white gutter mop is made of durable non-looped cotton strands. Recommended for all type gutters. Machine-washable.

- Gutter Mop - 159-4400
- Gutter Mop Frame and Handle only - 159-4400F
- Gutter Mop Complete with Frame and Handle - 159-4400C

Frames and Jaws ^{NEW!}

- 18" Wire Frame - 159-4450
- 24" Wire Frame - 159-4451
- 36" Wire Frame - 159-4452
- 48" Wire Frame without Brace Bar - 159-4453
- Jaws Snap on Handle - 159-4455



PIN CLEANING MACHINE & CLEANER SOLUTION

Physical Properties:

- Cleans ALL types of bowling pins
- Includes attachment to sand pins
- Weight: 37 pounds

Part Number:
17-0040 – 115V/60 Hz
17-0040E – 230V/50 Hz



Physical Properties:

- Cleans ALL types of bowling pins
- Not harmful to skin
- For use in ALL pin cleaning machines
- Weight: 1 gallon is approximately 8.7 pounds
- Packaging: 1 gallon bottle/box
- Concentrated cleaner
- pH: 8.75

Part Number: 156-8800



MOPPING TABLET



Fizzion Mopping Tablet is an all-purpose floor cleaner designed for bowling centers. Its formula was created to leave NO sticky residue so your bowlers' shoes stay clean both on and off the lanes.

- Mixes up fresh every time you mop for maximum power
- Cuts through dirt & grease with ease
- Easily lifts set-in grout stains
- Includes mild bleaching action
- Concentrated product reduces waste & pollution
- 45 pre-measured tablets to control cost
- One tablet makes 4 gallons

Part Number: 156-8565B

Pro Shop Products



Physical Properties:

- Keep your hands moisture-free
- Not sticky - No odor
- No white powder residue
- Lasts all day
- Cleans off with soap and water

Part Number:
156-8773 - 3oz. bottle
156-8773C - Case (10 - 3oz. bottles)

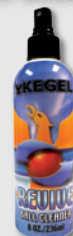

Physical Properties:

- pH: 8.4
- Easy to use - spray on, wipe off
- Gentle on the skin
- Can be used on ALL bowling balls
- Approved for use in USBC competition

Part Number:
156-8768 - 8oz. bottle
156-8768C - Case (12 - 8oz. bottles)
156-8762 - 32oz. bottle

TECHPOWER



24/7 Tech Support

Backed by Kegel's 30-minute guarantee

Tired of being forced into email or having to provide your credit card for tech support? We are too. That's why it's our culture to make sure you'll have a person to talk to when you need it most, 24 hours a day, 7 days a week.

Emergency Lane Maintenance calls will be answered immediately or returned in 30 minutes or less...guaranteed.

myKEGEL



my.kegel.net

Simplify your maintenance routine with this online lane machine management tool. Receive maintenance reminders, easily access manuals, service bulletins, and help videos, or quickly request parts from your preferred distributor.

myKegel is customized for your Bowling Center and lane machine.

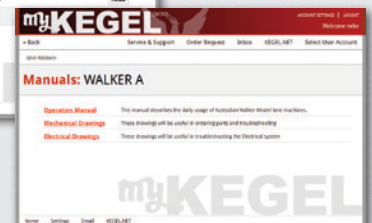
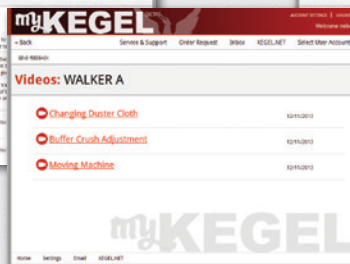
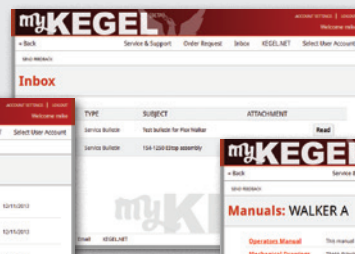

LEGEND

SUFFIX	MACHINE	SUFFIX	MACHINE
FXW	FLEX WALKER	STD	STANDARD
FLX	FLEX	PXS	SM II, PHOENIX S, BRUNSWICK ECHO
KW	KUSTODIAN WALKER	PX	PHOENIX
ION	KUSTODIAN ION	DT	DART
XF	CROSSFIRE	XL	EXCEL
KP	KUSTODIAN PLUS	LCM	LANEWALKER LANE CLEANING MACHINE
KK	KUSTODIAN	LW	LANEWALKER
EP	ELITE PLUS		
ELT	ELITE		

Suffix represents all model variations unless model type is specifically indicated (i.e. KP-A). Parts do not apply to original Sanction® Machines.

Cleaning

FLEX Cleaning System

Recovery Tank - 164-8017

Recovery Tank Filter (for tank 164-8017)

164-8017F - FXW | FLX (FLX-17733 / FXW-13229 and ABOVE)

Recovery Tank Filter (for tank 164-8017)

164-6114 - FXW | FLX (FLX-17732 / FXW-13228 and BELOW)

Cleaner Pump Motor Assembly - 158-8404

Cleaner Pump Assembly - 158-8404D

Norprene® Tubing - 154-0861B

Cleaner Supply Tank Float Switch - 154-8693

Complete Cleaner Tank Assembly (Standard)

164-8042

Cleaner Supply Tank Only (Standard)

164-6016



Upgraded Cleaner Mixing System

Complete Cleaner Tank Assembly - 164-8043

Cleaner Supply Tank Only - 164-6741

Complete Water Tank Assembly - 164-8041

Cleaner Water Tank Only - 164-6740

Cleaner Pump Assembly for Concentrate

164-8027

Cleaner Tubing #14 for Super Concentrate

164-8025

Cleaner Tubing #16 for Regular Concentrate

164-8026

Supply Tank Caps

164-6018

Cleaning

Recovery Tank - 153-8841 - XF | PXS-A,B | PX-A,B
Recovery Tank Filter (for tank 153-8841) - 153-8844 - XF | PXS-A,B | PX-A,B
Recovery Tank - 154-8683 - ION-A | KP-A | KK | ELT | STD | PXS-C | PX-C
Folded Recovery Tank Filter (for tank 154-8683) - 154-8684
Recovery Tank - 158-8434 - ION-B | KP-B
Recovery Tank - 158-8617 - KW | ION-C,D
Recovery Tank Filter (for tanks 158-8434 & 158-8617) - 158-0406
Recovery Tank Gasket (for tanks 158-8434 & 158-8617) - 158-0405



Vacuum Motor - See Motors on pages 28 & 30
Following Items are Not Pictured
Vacuum Housing - 153-0204H
Fan Blade - 153-0204F
Flexible Hose (Sold by the Inch) - 154-0260

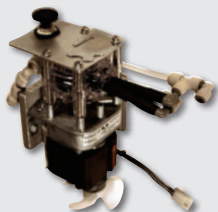

Cleaner Pump Drive Motor
154-8874 (115VAC)
154-8875 (230VAC)
158-8404 (24VDC)
Cleaner Pump Assembly - 158-8404D
Norprene® Tubing - 154-0861B
Cleaner Volume Control Valve - 154-1855
Cleaner Tip & Hose Assembly - 154-8852



5" Cleaner Tank Filter - 154-0212B
1/2" O-Ring - 154-0287C



Universal In-Line Filter Assembly - 154-8867A
In-Line Filter Assembly - 154-8887 - KW | ION | KP | EP

Cleaning System Tubing
(Sold by the Inch)
1/4" - 153-0208S - for Spray Jet Machines
1/4" - 154-0202C - Clear



Complete Supply Tank Assembly - 154-8840 - XF | KK | PX-C
Complete Cleaner Tank Assembly - 154-8680 - EP | ELT | STD | PXS-C
Complete Cleaner Tank Assembly - 158-8433C - KW | ION-B,C,D | KP-B
Cleaner Supply Tank Only - 158-8433 - KW | ION-B,C,D | KP-B
Cleaner Supply Tank Only - 154-8894 - ION-A | KP-A
Expandable Supply Tank Plug (1-1/2") - 153-0246A
Rubber Insert and Plug for Supply Tank - 153-0247

Potentiometer for Cleaner Control
154-8846 - KP
158-8413 - KW | ION

Complete Cleaner Pump Assembly
154-8859 (115VAC) - KP-A | EP
154-8859E (230VAC) - KP-A | EP
Complete Cleaner Pump Assembly
158-8404C (24VDC) - KW | ION
154-8847 (24VDC) - KP

Solenoid Valve (3-Way)
154-1851 (115VAC) - KP-A Only | EP
154-1852 (230VAC) - KP-A Only | EP

Kustodian PLUS
(Model A Only)
24VDC Cleaner Pump
Conversion Kit
154-8844 (115V)
154-8845 (230V)

Hose and Elbow Kit

With this kit, you will have all of the tubing and fittings to replace the plumbing in the cleaning system of your lane machine.

153-8887 - PX-A,B
154-8286 - PXS-A,B
154-8287 - PXS-C
154-8827 - KK-A,B,C
154-8677 - STD



Cushion Roller With Cloth Cover - 153-8839

Compatible with FXW | FLX | KW | ION | XF | KP | EP

Contact Tech Support for use on these models: KK | ELT | STD | PXS | PX

Cloth Cover Size

Size A - 154-8889A

Size B - 154-8889B

Size C - 154-8889C

Size D - 154-8889D

Size E - 154-8889E



Cushion Roller - 153-8838 - KK | ELT | STD | PXS | PX

Cushion Roller - 153-8026 - LW

Cushion Roller - 153-8238B - LCM



PVC Take-Up Reel - 153-8824

(Not required with K2 Select EZ Core Cloth)

PVC Take-Up Reel Clamp - 154-6248 (Not Pictured)

Complete Squeegee Assembly (Blue) - 153-0202D

KW | ION | XF | KP | KK | EP | ELT | STD | PXS-C

Complete Squeegee Assembly (Brown) - 153-0202A - PXS | PX

Complete Squeegee Assembly (Blue) - 153-0202 - LCM

Replacement Squeegee Blade & Gasket Kit - 164-8038K

FXW | FLX (also for machines with upgraded Squeegee Cartridge)

Squeegee Gasket - 164-0003 FLX | FLXW

Replacement Squeegee Blades - Blue pair - 153-8204E

Replacement Squeegee Blade - Individual - 153-0202E

Replacement Squeegee Blades - Brown pair - 153-8834

Replacement Squeegee Blade - Individual - 153-0202C

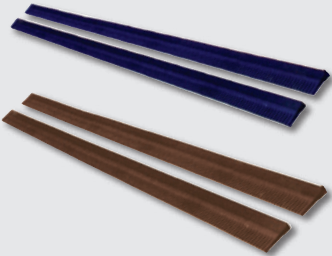

Spray Jet Cup Assembly Upgrade
154-8692



Spray Pressure Regulator Upgrade
154-8268

Cleaner Pump Repair Kit

Valve/Diaphragm Kit for Kegel Pump
158-8212K

Spray Jet Cleaner Pumps

Kegel Cleaner Spray Pumps

158-8212 (115V AC)

158-8213 (230V AC)

For older Standard AC and SE Machines with Pump Mounted Over Buffer Motor.

154-8651A (115V AC)

154-8652A (230V AC)



Spray Jet Assembly

Tip Retainer - 153-0218

Spray Jet Body - 153-6252

Nylon Body - 153-0217

Screen Check Valve - 153-0220

Outside Spray Tip (1501) - 154-0007

Inside Spray Tip (8003) - 153-0207

Inside Spray Tip (11003) - 153-0207A

Cleaner Tip Check Valve (Pkg of 5)

154-0862K - KW | ION | KP | EP

Cleaner Tip with Check Valve - 164-0012M

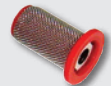
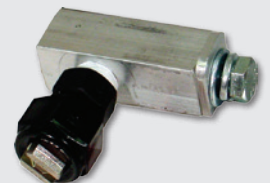

Cleaner Funnels

Cleaner Funnel - Long Stem

158-8252

Cleaner Funnel - Short Stem

154-8647

Cleaner Funnel - No Stem

153-0252



Conditioning

DUO™ System

Conditioner Transfer Brush Assembly - 164-0866



Buffer Brush - 164-8001 - FXW | FLX

Buffer Belt Standard - 164-9006 - FXW | FLX

Buffer Belt for Variable Speed Upgrade - 154-9615 - FXW | FLX
(FLX-17733 / FXW-13229 and ABOVE)

Buffer Belt for Variable Speed Upgrade - 164-9006 - FXW | FLX
(FLX-17732 / FXW-13228 and BELOW)

Belt for Conditioner Pumps - 164-9008 - FXW | FLX

Transfer Roller - 164-8008 - FXW | FLX

Transfer Roller Belt - 154-9203 - FXW | FLX

Pulse Suppression Assembly - 164-8021 - FXW | FLX

Pressure Gauge (60 psi) - 158-1613

Oil Control Valve (24V DC - Extended Wires with Fittings)

154-8298 - FXW | FLX

Oil Vent Valve Assembly - 164-8007 - FXW | FLX



FLEX Conditioner Cartridge

(Complete with Valve Assembly) - 164-8015 (Pkg of 2)

FLEX Conditioner Cartridge

(Without Valve Assembly) - 164-8015A

Cartridge Plunger - 164-8015P

Cartridge Cap (with 38mm hole)

164-0004

Valve Gasket for Cap

164-0002

Viton O-Ring for Plunger (outside)

164-6079

FLEX Conditioner Sub Tank

164-8016

FLEX Conditioner Sub Tank Float Switch

154-8693

FLEX Conditioner Sub Tank Filter Assembly

154-0212

Conditioner Transfer System



Conditioner Transfer Brush Assembly - 154-0866 - KW | ION | KP | EP



Buffer Brush - 154-8641 - KW | ION | XF | KP | KK | EP | ELT | STD | PXS-C | PX-C

Buffer Brush - 153-8407 - PXS-A,B | PX-A,B | DT | XL

Buffer Brush - 153-8017 - LW



Transfer Roller - 153-8408 - PX-A,B | DT | XL

Transfer Roller - 154-8338 - PX-C

Transfer Roller (2.25 diameter) - 154-8207 - PXS-A,B

Transfer Roller (1.75 diameter) - 154-8208 - PXS-A,B

Transfer Roller - 154-8608 - KK | ELT | STD | PXS-C

Transfer Roller - 158-8204 - XF



Buffer Belt - 154-9615 - ION-A,B | KP | KK | EP | ELT | STD | PXS-C

Buffer Belt - 153-9015 - PXS-A,B | PX-A,B | LW

Buffer Belt - 153-9817 - PX-C

Buffer Belt - 158-9201 - XF

Buffer Belt - 158-9026 - KW | ION-D



Head Drive Belt - 154-9201

Compatible with ALL applications.

Fluid Metering Components

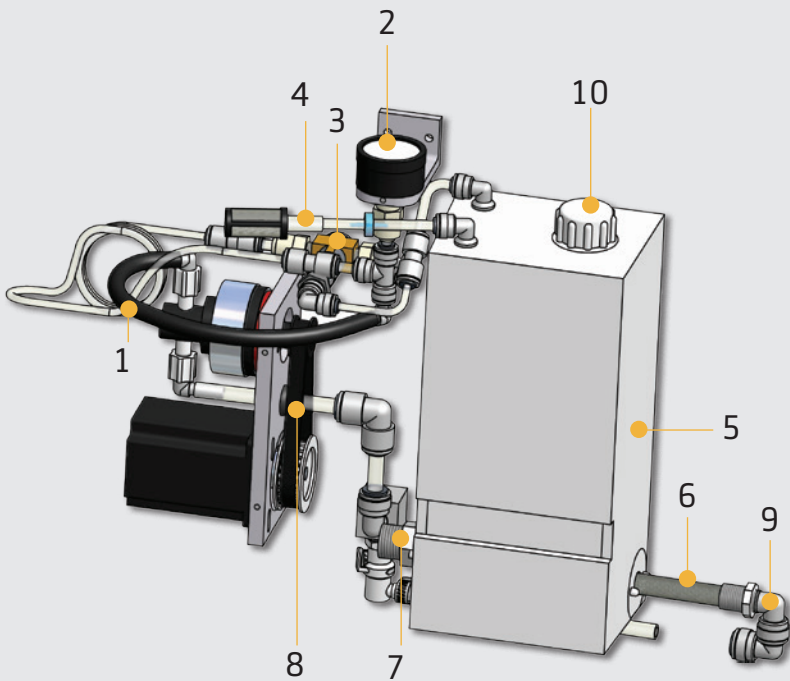

1. Pulse Suppression Assembly

164-8021 - FXW | FLX
 154-8660 - EP | ELT | STD | PXS-C
 154-8216K - PXS-A,B
 154-8816 - KW | ION | KP | KK

2. Pressure Gauge (60 psi) - 158-1613 (Replaces 154-1225)

3. Oil Control Valve (24V DC) - 154-1209

Oil Control Valve (24V DC - Extended Wires & Fittings) - 154-8298
 Calibration Valve (115V AC) - 154-1210 - PXS-A,B (Not Pictured)

4. Vent Valve - 154-8817 (Electrical Vent Valve Discontinued)

5. Oil Tank Assembly with Fittings/Float

154-8682 - KW | ION | KP | EP | ELT | STD | PXS-C

Oil Tank Assembly with Fittings

154-8842 - KK

6. Oil Tank Filter - 154-0212

7. Float Switch Assembly

154-1203 - XF

154-8693 - KW | ION | KP | EP | ELT | PXS-C | PX-C

154-8203 - PXS-A,B (3" Vertical for tank 154-8201C)

154-8203A - ELT | STD (7" Vertical for tank 154-8615C)

8. Belt for Conditioner Pump Motor

154-9202A (60Hz) 154-9215 (50Hz)

9. Elbow $\frac{3}{8}$ " Tube x $\frac{1}{4}$ " NPT - 154-0225

10. Oil Tank Cap Assembly

154-0832 - Complete

154-0832C - Cap only

154-0832G - Gasket only

Tubing

Conditioning System Tubing

(Sold by the Inch)

$\frac{3}{16}$ " - 154-0202B

$\frac{1}{4}$ " - 154-0202A

$\frac{3}{8}$ " - 154-0202

Conditioner Head Tip & Hose Holder Assembly (includes tubing)

1- $\frac{1}{4}$ " Tip Holder (PXS only) - 154-8285

3- $\frac{1}{2}$ " Tip Holder (Painted Machines with Transfer Roller) - 154-8883

4- $\frac{1}{2}$ " Tip Holder (Painted Machines with Transfer Brush) - 154-8851

5- $\frac{1}{4}$ " Tip Holder (Upgraded Transfer Brush Models) - 154-8896

Retaining Spring for Head - 153-2713

Oil Pencil Tip (Black Molded) - 154-6832

Replacement Felt

Felt ($\frac{1}{8}$ " x 3") - (Sold by the Inch) - 154-0228S

Felt Strip on Splash Guard Tank - 154-8333 - PX-C Only

Felt Kit for Transfer and Spray Jet Wall

154-8669 - KK | ELT | STD | PXS-C

Felt for LDS Splash Guard

154-8690 - Painted Sanction Technology™ Machines

Felt Strip for Transfer Wall - 154-8669A - KW | ION | KP | EP

Graduated Cylinder (25ml) - 154-0215

Felt for Graduated Cylinder (25ml) - 154-0210

Graduated Cylinder (50ml) - 154-0215A

Felt for Graduated Cylinder (50ml) - 154-0210A

Oil Funnel with 3" Hose - 153-0052A

Funnel with Connecting Stem for

Conditioner Tank (Small) - 154-8648

Fluid Metering Oil Pump

154-1214



A. O-Ring for Fluid Metering Pump

(Orange) - 154-1214E

B. Gland Seal for Fluid Metering Pump (White) - 154-1214D

C. Lip Seal for Fluid Metering Pump (Red) - 154-1214A

Wicks



Glueless Wick Plate Assembly

- 3" - 153-8103A Replacement for glued wicks
- 3.125" - 153-8123 Only Compatible with PX-C
- 3.125" - 158-8223 Only Compatible with XF



- 5" - 153-8105A Replacement for glued wicks
- 5.125" - 153-8125 Only Compatible with PX-C
- 5.125" - 158-8225 Only Compatible with XF



- 7" - 153-8107A Replacement for glued wicks
- 7.125" - 153-8127 Only Compatible with PX-C
- 7.125" - 158-8227 Only Compatible with XF

- 10" - 153-8110A Replacement for glued wicks
- 10.125" - 158-8230 Only Compatible with XF

Not Pictured

- 45" Wick Material for Glued Wicks - 153-0005 (4")
- 45" Wick Material for Glueless Wicks - 153-0005B (5")
- Wick Material Stock for Glueless Wicks - 153-0005D
(Custom cut to be purchased by the inch)



- Wick Spring (0.438 OD x 2.75) - 153-2095
- Wick Spring (XF Only) - 153-2740

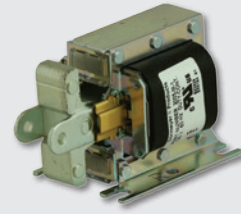

- Solenoid (115V) - 153-1027
- Solenoid (220V) - 153-1627
- Solenoid Cable Assembly 7.625" 153-8812 (PX-A,B)
- Solenoid Cable Assembly 8.25" 153-8812A (PX-C)

Pattern Smoothing Pads

- Pattern Smoothing Assembly - 154-8617
- Velcro for Smoothing Pad 154-8617V (10 per pack)
- Smoothing Pad Spring 153-2540A

PLC



- 1
- 2
- 3
- 4

C200HS Components

1. Input Module ID212 - 153-1816
2. Output Module OC221 - 153-1814
3. Output Module OC222 - 153-1815
4. Mounting Rack C200H - 153-1811

Not Pictured

PLCs No Longer Available:

SP-16 PLC / C28H PLC / C200HS PLC

Call 863-734-0200 for more information.

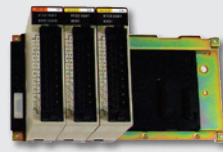

- 1
- 2
- 3

C200HG Items

1. Input Module ID212 - 153-1816
2. Output Module OC222 154-8231 (With 24VDC Relay)
3. Mounting Rack C200HW - 154-1201B



C200HG PLC
154-1201



Power Supply
C200HG - 154-1201P

Twido® PLCs (Crossfire Only)

- Programmable Logic Controller
- Please contact KEGEL for correct part number for your model.
- Real Time Clock - 158-1201C
- Connector (RS485 Mini-DIN) - 158-1201D
- Output Module - 158-1202
- Keypad Cable - 158-1203C
- Keypad Assembly - 158-8209
- Twido® PLC Battery - 155-1246



Touchscreen Components

- Touchscreen Display - 158-8671 - KW C,D | ION C,D
- Touchscreen Display - 164-8011 - FXW | FLX
- Touchscreen Protector - 158-1612
- Touchscreen Mounting Clip - 158-1610TC



PLC Components

- CP1HX PLC - 158-1610P
- Serial Port Converter for CP1 - 158-1610S
- Analog Output - 164-1217 - FXW | FLX
- Communication Cable - 158-1610D - FXW | FLX
- Communication Cable - 158-1610CC - KW C,D | ION C,D



CPM2A PLC

- 154-1801 (115VAC / 230VAC)
- 158-1423 (24VDC)

Not Pictured

154-1801M - PX-C Expansion Module

Omron® PLC Battery

- 153-1001C - C28H | C200H
- 154-1804 - CPM2A

Keypad

- 154-8806 - ION | KP | KK
- 154-8806C - XF (Omron®)
- 154-8807 - PX-C
- 154-8808 - Firebird

Keypad Overlay Decal

- 158-0802 - KW-B
- 154-0801 - ION | KP | KK
- 154-0251 - ELT | STD | PXS
- 158-0204 - XF (Twido®)
- 154-0801K - XF (Omron®)
- 153-0844 - PX-C
- 153-0844F - Firebird
- 153-0801 - PX
- 153-0025 - LCM | LW

Keypad Cable - 154-1803

- Keypad Mounting Clips (set of 2) - 154-1802C

KOSI Kegel Online Support Interface

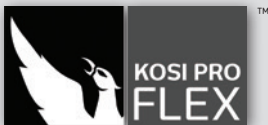

KOSI Pro Kit for FLEX - 154-8781

- USB to Serial Converter
- KOSI Cable (32 or 64 bit)
- USB Drive



KOSI PRO Software

KOSI Pro Kit for Kustodian - 154-8771

- USB to Serial Converter
- KOSI Cable (32 or 64 bit)
- KOSI Software CD

KOSI Pro Kit for C200H PLC - 154-8771A

- USB to Serial Converter
- RS232 Converter Module for KOSI Cable (for Omron® C200HG & C200HS)
- KOSI Cable (32 or 64 bit)
- KOSI Software CD

KOSI PRO UPDATE (7.x) - 154-8771U

KOSI PRO UPGRADE (5.x/6.x to 7.x) - 154-8771C

KOSI Communication Kit - 154-8771B

- USB to Serial Converter
- KOSI Cable (32 or 64 bit)



USB to Serial Converter
157-1057



USB Drive
154-8781U



RS232 Converter Module
for KOSI Cable
(for Omron® C200HG & C200HS) 154-1614



KOSI Cable
(32 or 64 bit) - 154-8724

Batteries & Chargers



Kegel K2 Energy® Lithium Batteries

158-1634C (51.2 Ah)

158-1634B (38.4 Ah)

158-1634 (25.6 Ah)



**ProNautic®
Chargers**



**ProTech®
Chargers**

Chargers		
Machine Type	115V	230V
ION-A,B (AGM)	158-8470	158-8470
ION-A,B (Lithium)	158-8472	158-8472
ION-C,D	164-8471P	164-8471PE
FXW FLX KW	164-8471	164-8471E

Charger Replacement DC Cables	Description
158-8474	ProTech DC power cord assembly - 1 FT Internal
158-8475	ProTech DC power cord assembly - 6 FT External
164-8475	ProNautic DC power cord assembly - 6 FT External
158-1407	Battery Disconnect Housing - Red
158-1408	Battery Disconnect Housing - Blue

Batteries				
Machine Type	Lanes Per Charge	KEGEL Charger Being Used	Battery Available	Kit Needed
ION-A,B	Up to 32	Any	158-8651 (AGM)	None
	Up to 40	ProTech	158-1634 (Lith)	158-8654
	Up to 62	Any	158-1634B (Lith)	158-8654
KW-A,B	Up to 32	Any	158-8651/158-8651C (AGM)	None
	Up to 40	ProTech/ProNautic	158-1634 (Lith)	158-8655
	Up to 62	Any	158-1634B (Lith)	158-8655
KW ION-C,D	Up to 32	Any	158-8651 (AGM)	None
	Up to 40	ProTech/ProNautic	158-1634 (Lith)	158-8655
	Up to 60	Any	158-8652 (AGM)	None
	Up to 62	Any	158-1634B (Lith)	158-8655
	Up to 90	Any	158-1634C (Lith)	158-8655
FXW FLX	Up to 40	ProNautic	158-1634 (Lith)	None
	Up to 62	ProNautic	158-1634B (Lith)	None
	Up to 90	ProNautic	158-1634C (Lith)	None

Replacement Batteries & Accessories



Odyssey® PC680 Batteries

(Sold in Pairs) - 158-8650

Odyssey® PC925 Batteries

(Sold in Pairs) - 158-8651

Odyssey® PC1200 Batteries

(Sold in Pairs) - 158-8652

DC Voltage Regulator - 158-8417

Smart Charger (IQ-4) - 158-1452 for IOTA® Battery Chargers

LCD Amp Gauge Assembly - 158-8410 KW | ION

NOTE: Battery voltage must be closely matched on both batteries for best performance.

Electrical Components

Power Cord Components

Description	115V AC	230V AC
Power Cord PX-A,B	153-8810	153-8811A
Power Cord PXS-A,B	154-8229A	154-8230
Power Cord EP ELT STD PXS-C	154-8629	154-8630
Power Cord ION XF KP KK PX-C	154-8829	154-8830
Male Plug End (15A)	153-1025	153-1625
Male Plug End (20A)	153-1825	N/A
Female Twistlock Plug (15A)	153-1024	153-1624
Female Twistlock Plug (20A)	153-1822	153-1824
25' Charging Cord Assembly KW ION-A,B	158-8425	158-8425E
Velcro Strap For Cord	154-0242	154-0242

Push Button Replacements

Handle Button Replacement Assembly - 164-8013 - FLX
 Handle Wire without Connector - 153-8424A
 Handle Wire with Kill Plugs - 153-8424C - PXS-A,B | PX-A,B
 Handle Wire - 154-8893B - ION | KP
 Handle Wire - 154-8624 - ELT | STD | PXS-C
 Handle Button Replacement Assembly - 154-8824 - KK

Head Motor 6.0µF Capacitor

154-1208 - KP | KK | EP | ELT | STD | PXS

Oil Pump Motor 1.5µF Capacitor

154-1208B - KP | KK | EP | ELT | STD | PXS

Arc Suppressor

158-1438

Breakers



Circuit Breaker 8A - 153-1810
 Circuit Breaker 10A - 153-1030
 Circuit Breaker 20A (24V DC) - 158-1451



Rocker Breaker 15A - 154-1610
 Rocker Breaker 10A - 154-1272

Blade Type Fuses

Fuse 25A - 158-1439 for CVR - KW | ION
 Fuse 30A - 164-1214 for CVR on VB Upgrade and Pro Nautic® Charger - FXW | FLX
 Fuse 40A - 158-1440 for IOTA® Battery Chargers
 Maxi-Fuse 40A (for Fuse Link) - 158-1454 - ION
 Fuse Link Assembly - 158-8421 - ION

Fuse & Relay Kit



With these kits, you will have all of the small electronic pieces needed to keep you going. These kits contain three of each fuse used in the machine as well as fuse holders, spare relays, buttons and switches.

154-8600F - STD | PXS-C
 154-8600G - STD | PXS-C
 154-8800F - KK-A,B
 154-8800G - KK-A,B
 154-8800J - KK-C
 154-8800K - KK-C
 154-8800R - KP
 154-8800S - KP
 158-8600F - KW-A,B | ION-A,B
 158-8600G - KW-C,D | ION-C,D
 164-8100F - FXW | FLX

Fuses

Panel Mount Fuse Holder (115V) - 153-1028
 Fuse 0.5A (UL) - 154-1261
 Fuse 0.75A (UL) - 154-1262
 Fuse 1A (MDL) - 155-1229
 Fuse 1.8A (UL) - 154-1265
 Fuse 2.25A (UL) - 154-1266
 Fuse 3.2A (UL) - 154-1267
 Fuse 4A (UL) - 154-1268C
 Fuse 7.5A (UL) - 154-1270
 Fuse 8A (UL) - 154-1270C
 Fuse 10A (UL) - 154-1273
 Fuse 20A (UL) Ceramic - 154-1274C
 Fuse 20A (UL) - 154-1274
 Fuse 25A (MDA) Ceramic - 164-1222

Panel Mount Fuse Holder (230V) - 153-1028E
 Fuse 315mA (IEC - 230V) - 154-1260E
 Fuse 500mA (IEC - 230V) - 154-1261E
 Fuse 1A (IEC - 230V) - 154-1264E
 Fuse 1.6A (IEC - 230V) - 154-1265E
 Fuse 4A (IEC - 230V) - 154-1267E
 Fuse 6.3A (IEC - 230V) - 154-1269C

Electrical Components

Omron® Brand Relays



LY2 Relay
153-1016D (24V DC Coil)
LY2 Relay
153-1016 (115V)
153-1616 (230V)



LY3 Relay
153-1018 (115V)
153-1618 (230V)



LY4 Relay
153-1406 (115V)
154-1611 (230V)



MY4 Relay
(24V DC)
158-1427

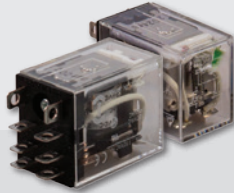

DPDT 10A
158-1462



PLC Output Relay (Short)
153-1032 (for Output Module OC221/OC222)
PLC Output Relay (Tall)
154-1215 (24V DC Coil - for Output Module OC222 only)

Omron® Relays for Sport Edition / FLEX Model

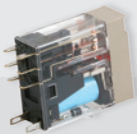

24VDC DPDT
158-1458



Solid State
158-1460



Super MY4 24V DC
(with Diode)
158-1463

Phoenix® Brand Relays



Secondary Relay Assembly
(24V DC)
154-1835 - KP | KK



2 Pole
(10A - 24V DC)
158-1420G

Automation Direct® Relays



2 Pole
(15A - 24V DC)
158-1413

Other Electrical Components



Duster Microswitch
(Large) 154-1603
FXW | FLX | KW | ION | KP |
KK | EP | ELT | PXS-C | PX-C



Duster Microswitch
(Small) 153-1202
XF | PXS-A,B | PX-A,B



Microswitch with Roller
153-1203
for ALL Machines



Squeegee Microswitch
(Large) 154-1015
KK | ELT | STD | PXS-C |
PX-C



Pass-Through Sensor
153-1031A



Sensor Plug and Cable
153-1031B



Proximity Sensor
154-1220

Proximity Sensor
158-1208 - XF-A



Contactor 24VDC
158-1465
(Used for Sport Edition Vacuum
& Auto Shutdown Relay)



Red Push Button
(Normally Open)
153-1408

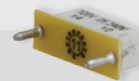

Horsepower Resistor
0.025 Ω - 153-1015A
Horsepower Resistor
0.050 Ω - 153-1015



FLEX E-Stop Assembly - 164-1223
(Includes breaker, black box sold separately)
FLEX E-Stop Breaker - 164-1223B
Prior to serial #FLX-17802 / FXW-13306 use part number 164-1223
(This will replace the discontinued breaker and red triangle shaped
e-stop assembly)



2008 E-Stop (2-Hole Pattern)
154-1250A
Breaker for E-Stop
(2008 and later)
154-1251A

VOLTMETER TIPS



VOLTMETER SYMBOLS



Alternating Current
V AC
All 115V and 230V machines
that utilize a power cord



Direct Current
V DC
All battery operated
machines / also used to
drive AC powered machines.



Continuity Check
Used to inspect fuses and
circuitry. A beep will sound
when fuse or circuit is
closed.

BASIC VOLTMETER OPERATIONS

To check voltage:

1. Turn dial on the voltmeter to desired test.
2. Place each probe into the wires of the component you are testing and turn component on.

To check continuity:

1. Touch both probes together to inspect the voltmeter for proper function.
2. Place the test probes at each end of the circuit to be tested.
3. Voltmeter will sound if circuit is not broken. No sound if there is a break in the line.

TECH TIP:

Always inspect power cord ends and battery connections when electrical problems occur.

Upgrades

DUO™ Transfer System

Old Style Transfer Brush System to DUO System

158-8430F

Smoother Pad Transfer System to DUO System

158-8430N - All painted machines only



Complete Squeegee Cartridge Assembly

164-8038

Handle Reinforcement Kit

154-8284 - for ALL machines except FXW | KW | LCM | LW

Crossfire Upgrades

Complete Upgrade - Includes 8 Wicks with Cam

Roller and Large Conditioner Supply Tank

158-8241 (115V) | 158-8241E (230V)

Conditioner Tank Upgrade

158-8215 (115V) | 158-8215E (230V)

8 Pad Wick & Cam Kit - 158-8214

TWIDO® to OMRON® PLC Conversion Kit

158-8253

Proximity Upgrades

Lane Distance Sensor (LDS)

Upgrade with Proximity Sensor

LDS (Right) PXS-A,B 154-8291

LDS (Center) PXS-A,B | PX-A,B 154-8292

LDS (Center) STD 154-8672

Tach (Internal) PXS-A,B 154-8289

Tach (External) STD | PXS-A,B 154-8290

Head Timing STD | PXS-A,B 154-8673

LED Light Upgrade Kit for Supply Tanks

Easily monitor the level of supplies on machines with plastic molded tanks with this light that automatically illuminates when the splash guard is opened.

158-8672 KW | ION | KP-A,B

Oil Tank Upgrade Kit for PXS-A,B - 154-8841

This upgrade will allow the operator to change the microliter per board setting without the hassle of lifting the machine. Best of all, the new durable plastic molded tank is "see through" so it is easy to check the oil level and perform preventive maintenance.

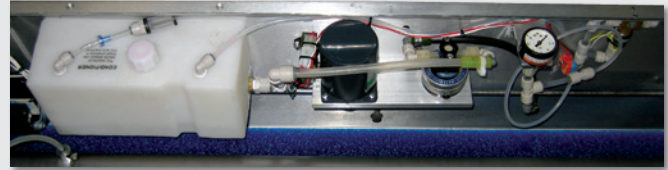

Wheel Upgrades



6" Front Wheel Upgrade

Large 6" front wheel helps the lane machine transition on and off the lane with ease.

158-8733 ION | KP-B

3" Caster Upgrade

Dual 3" rear casters allow for better machine transition on and off the lane.

158-8731 KW | ION-C,D

158-8732 ION-A,B | KP-B

Transport Caster Upgrade - 154-8281 PXS-A,B | PX



Power Button Relocation Kit

Relocate the power button to the splash guard allowing for easy access to turn the unit on.

158-8673 KW-D | ION-D

Kustodian Proximity and Relay Upgrades

Kustodian Model A to C Upgrade Kit - 154-8870

Serial Number: KK-0600 through KK-0810

Kustodian Model B to C Upgrade Kit - 154-8871

Serial Number: KK-0811 through KK-0987



BEFORE



AFTER

Miscellaneous

LDS Shaft Assembly

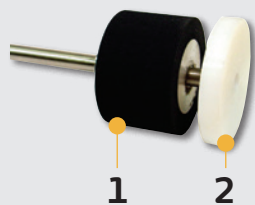

- 1. Wheel - 153-7002AA
- 2. Kick Up Wheel - 153-7401

Tune Up Kits



- FXW | FLX - 164-8030
- KW - 158-8628
- ION - 158-8428
- KP | EP (115V) - 154-8686
- KP | EP (230V) - 154-8687
- KK | ELT | PXS-C | PX-C (115V) 154-8888
- STD (115V) - 154-8688
- PX-B (115V) - 153-8888
- PXS-A,B (115V) - 154-8288

Non-Adjustable Guide Rollers

- Guide Roller - 153-8410
- Guide Roller - 153-8310 - LCM | LW
- Guide Roller Shoulder Bolt - 153-2407
- Guide Roller Mounting Bar - 153-6417
- Guide Roller Spring - 153-2401
- SHCS 1/4-20 x 2-3/4" - 153-2211

Adjustable Guide Rollers



- Complete Front Assembly - 158-8643
- Front Wheel Only - 158-8637
- Complete Rear Assembly - 158-8642
- Rear Wheel Only - 158-8636
- Compression Spring - 153-2978

Whiskers

- Whisker Spring - 153-2946 - KW
- Black Vinyl Cap - 153-2941 - KW
- Complete Assembly - 158-8623 - KW
- Whisker Assembly - 164-8660 - FXW

Momentary Wheel Assembly

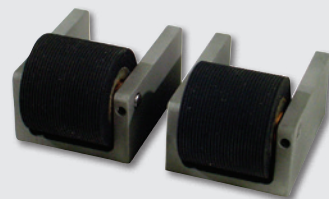

- Wheel - 153-7005R
- Shaft - 153-6006
- Housing - 153-6029

Caster Wheels

- Lane to Lane Caster 2" 153-0812 (Heavy Duty) Transport Caster



- 3" Dual Wheel (Black) - 153-0001BK
- 3" Dual Wheel (Gray) - 153-0001
- 2" Single Wheel - 153-0002



- FLEX Whisker Upgrade 158-8624 - KW

Lid & Component Assemblies



- Middle Slide Latch 154-0005



- Flush Mount Lid Latch (Without Lock) - 153-2232A



- Straight Quarter-turn Lid Latch (With Slot) - 154-0804



- Push Latch with Key 154-0881



- Flush Mount Lid Latch (With Lock) - 153-2232L



- Flange Quarter-turn Lid Latch 154-0805



- Rubber Bumper - 154-0006A



- Foam (Sold by the Inch) - 153-0036



- Lid Pin - 164-2002

Motors & Speed Controls

Sanction Technology™

COMPONENTS	PXS-A,B	PXS-C STD AC	KK KP	KW-A,B ION-A,B	KW-C,D ION-C,D	STD SE ELT EP	FLX	FXW
Blower Motor (115V AC)	153-8801	N/A	N/A	N/A	N/A	N/A	N/A	N/A
Blower Motor (230V AC)	153-8802	N/A	N/A	N/A	N/A	N/A	N/A	N/A
Buffer Motor (115V AC)	153-8016A	154-8616A	154-8616A	N/A	N/A	154-8616B	N/A	N/A
Buffer Motor (230V AC)	153-8616	154-8616E	154-8616E	N/A	N/A	154-8616E	N/A	N/A
Buffer Motor (24V DC) - Standard	N/A	N/A	N/A	158-8414	158-8414	N/A	158-8414	158-8414
Buffer Motor (24V DC) - Variable Speed Upgrade	N/A	N/A	N/A	N/A	N/A	N/A	164-8014	164-8014
Buffer Motor Brushes (24V DC)	N/A	N/A	N/A	158-1406B	158-1406B	N/A	158-1406B	158-1406B
Buffer Motor Contactor (115V AC)	153-1004	153-1004A	153-1004A	N/A	N/A	153-1004A	N/A	N/A
Buffer Motor Contactor (230V AC)	153-1604	153-1604A	153-1604A	N/A	N/A	153-1604A	N/A	N/A
Conditioner Pump Motor (115V AC)	154-8234	154-8604	154-8604	N/A	N/A	154-8604	N/A	N/A
Conditioner Pump Motor (230V AC)	154-8234	154-8604E	154-8604E	N/A	N/A	154-8604E	N/A	N/A
Conditioner Pump Motor (24V DC)	N/A	N/A	N/A	158-8401A	158-8632	N/A	158-8632	158-8632
Conditioner Pump Motor Brushes (24V DC) BISON	N/A	N/A	N/A	158-1422B	N/A	N/A	N/A	N/A
Conditioner Pump Motor Brushes (24V DC) GROSCHOFF	N/A	N/A	N/A	158-1422G	N/A	N/A	N/A	N/A
Drive Motor (90V DC)	153-8065	153-8065 - STD	154-8865	N/A	N/A	153-8065 - STD	N/A	N/A
Drive Motor (90V DC)	N/A	154-8365 - PXS-C	N/A	N/A	N/A	154-8365 - ELT EP	N/A	N/A
Drive Motor (24V DC)	N/A	N/A	N/A	158-8406 - ION	N/A	N/A	N/A	N/A
Drive Motor (24V DC) Long Shaft	N/A	N/A	N/A	158-8602 - KW	158-8602	N/A	158-8602	158-8602
Duster Motor (115V AC)	153-8403	153-8403	153-8403	N/A	N/A	153-8403	N/A	N/A
Duster Motor (230V AC)	153-8803H	153-8803H	153-8803H	N/A	N/A	153-8803H	N/A	N/A
Duster Motor (24V DC)	N/A	N/A	N/A	158-8403	158-8403	N/A	158-8403	158-8403
Head Drive Motor (115V AC)	154-8232	154-8232	154-8232	N/A	N/A	154-8232	N/A	N/A
Head Drive Motor (230V AC)	154-8232	154-8632	154-8632	N/A	N/A	154-8632	N/A	N/A
Head Drive Motor (24V DC)	N/A	N/A	N/A	158-8405	158-8632	N/A	164-8032	164-8032
Head Drive Motor Brushes (24V DC)	N/A	N/A	N/A	158-1404B	N/A	N/A	N/A	N/A
Squeegee & Brush Lift Motor (115V AC)	153-8207	153-8207	153-8207	N/A	N/A	153-8207	N/A	N/A
Squeegee & Brush Lift Motor (230V AC)	153-8807H	153-8807H	153-8807H	N/A	N/A	153-8807H	N/A	N/A
Squeegee & Brush Lift Motor (24V DC)	N/A	N/A	N/A	158-8402	158-8402	N/A	158-8402	158-8402
Transfer Roller Motor (115V AC)	154-8206	154-8206	154-8206	N/A	N/A	154-8206*	N/A	N/A
Transfer Roller Motor (230V AC)	154-8206A	154-8206A	154-8206A	N/A	N/A	154-8206A*	N/A	N/A
Vacuum Motor (115V AC)	153-8205	154-8805	154-8805	N/A	N/A	154-8805	N/A	N/A
Vacuum Motor Brushes (115V AC Pair)	153-0204B	153-0204B	153-0204B	N/A	N/A	153-0204B	N/A	N/A
Vacuum Motor (230V AC)	153-8805	154-8805E	154-8805E	N/A	N/A	154-8805E	N/A	N/A
Vacuum Motor Brushes (230V AC Pair)	153-0204C	153-0204C	153-0204C	N/A	N/A	153-0204C	N/A	N/A
Vacuum Motor (24V DC)	N/A	N/A	N/A	158-8407	158-8407	N/A	158-8407	158-8407
Vacuum Brushes (24V DC Pair)	N/A	N/A	N/A	158-1421B	158-1421B	N/A	158-1421B	158-1421B

* Not used on Kustodian PLUS or Elite PLUS

COMPONENTS	PXS-A,B	PXS-C STD AC	KK KP	KW-A,B ION-A,B	KW-C,D ION-C,D	STD SE ELT EP	FLX	FXW
Circuit Board w/Speed Relays (115V AC)	154-8210	154-8312	154-8810	N/A	N/A	N/A	N/A	N/A
Circuit Board w/Speed Relays (230V AC)	154-8210	154-8644	154-8811	N/A	N/A	N/A	N/A	N/A
Circuit Board w/Speed Relays (24V DC)	N/A	N/A	N/A	158-8409	N/A	N/A	N/A	N/A
Isolator Analog Card 115V AC Drive Assembly	N/A	N/A	N/A	N/A	N/A	154-8633	N/A	N/A
Isolator Analog Card 230V AC Drive Assembly	N/A	N/A	N/A	N/A	N/A	154-8634	N/A	N/A
Isolator Analog Card 115V AC Buffer Assembly	N/A	N/A	N/A	N/A	N/A	154-8635	N/A	N/A
Isolator Analog Card 230V AC Buffer Assembly	N/A	N/A	N/A	N/A	N/A	154-8636	N/A	N/A
Isolator Analog Card Only	N/A	N/A	N/A	N/A	N/A	154-1413	N/A	N/A
Speed Control Assembly (24V DC-Buffer/ Drive)	N/A	N/A	N/A	N/A	N/A	N/A	164-8010	164-8010
Speed Control Assembly (24V DC-Drive)	N/A	N/A	N/A	158-8412	158-8412	N/A	N/A	N/A
Speed Control Assembly (24V DC-Cleaner Pump)	N/A	N/A	154-8848 KP	158-8415	158-8415	N/A	158-8415	158-8415
Speed Control Assembly (0i/Cleaner Head)	N/A	N/A	N/A	N/A	158-1605	N/A	158-1605	158-1605
Speed Control Board Only (115V AC)	153-1012	153-1012	153-1012	N/A	N/A	153-1012	N/A	N/A
Speed Control Board Only (230V AC)	153-1812	153-1812	153-1812	N/A	N/A	153-1812	N/A	N/A
Speed Control Board Only (24V DC)	N/A	N/A	N/A	158-1410	158-1410	N/A	158-1410	158-1410



Where do you want to howl today?

KEGEL
LANDMARK PATTERNS

Visit www.kegel.net for more information.

Motors & Speed Controls

Wick-Pad Technology

COMPONENTS	PX-A,B	PX-C	XF
Blower Motor (115V AC)	153-8801	N/A	N/A
Blower Motor (230V AC)	153-8802	N/A	N/A
Buffer Motor (115V AC)	153-8016A	154-8616A	154-8616A
Buffer Motor (230V AC)	153-8616	154-8616E	154-8616E
Buffer Motor Contactor (115V AC)	153-1004	153-1004A	153-1004A
Buffer Motor Contactor (230V AC)	153-1604	153-1604A	153-1604A
Drive Motor (90V DC)	153-8065	154-8865	154-8865
Duster Motor (115V AC)	153-8403	153-8403	153-8403
Duster Motor (230V AC)	153-8803H	153-8803H	153-8803 H
Squeegee & Brush Lift Motor (115V AC)	153-8207	153-8207	153-8207
Squeegee & Brush Lift Motor (230V AC)	153-8807H	153-8807H	153-8807
Transfer Roller Motor (115V AC)	153-8828	154-8332	153-8828
Transfer Roller Motor (230V AC)	153-8829	154-8332E	153-8829
Vacuum Motor (115V AC)	153-8205	154-8805	158-8208
Vacuum Motor Brushes (115V AC Pair)	153-0204B	153-0204B	153-0204B
Vacuum Motor (230V AC)	153-8805	154-8805E	158-8208E
Vacuum Motor Brushes (230V AC Pair)	153-0204C	153-0204C	153-0204C
Circuit Board w/Speed Relays (115V AC)	N/A	154-8330	N/A
Circuit Board w/Speed Relays (230V AC)	N/A	154-8331	N/A
Speed Control Assembly (115V AC 3-Speed)	153-8822	N/A	N/A
Speed Control Assembly (230V AC 3-Speed)	153-8823	N/A	N/A
Speed Control Assembly (115V AC 4-Speed)	153-8842	N/A	N/A
Speed Control Assembly (230V AC 4-Speed)	153-8843	N/A	N/A
Speed Control Assembly (115/230V AC 3-Speed)	N/A	N/A	158-8211
Speed Control Board Only (115V AC)	153-1012	153-1012	158-1212R
Speed Control Board Only (230V AC)	153-1812	153-1812	158-1212R

For Dayton® Drive Motor - 153-8065

Rear Seal - 153-1057R
 Front Seal (Shaft Side) - 153-1057S
 Gasket - 153-1057F
 Drive Motor Brushes (90V DC Pair) - 153-1057H

For ALL Baldor® Drive Motors

Rear Seal - 154-1809D
 Front Seal (Shaft Side) - 154-1809E
 Drive Motor Brushes (24V DC Pair) - 158-1405B
 Drive Motor Brushes (90V DC Pair) - 154-1809B

Fittings

Look for our new complete hose and elbow kits on page 16.



Elbow
1/4" Tube x 1/4" Tube - 154-0243



Elbow
3/8" x 3/8" - 154-0256



Elbow
3/8" NPT x 1/4" Tube - 154-0412
3/8" NPT x 3/8" Tube - 154-0803



Elbow
3/8" Tube x 1/4" NPT - 154-0225
1/4" Tube x 1/4" NPT - 154-0223



Elbow
1/4" Stem x 1/4" Hose Barb
154-0226



Elbow
1/4" Stem to 5/16" Hose Barb
154-0227



Elbow
3/8" Stem to 5/16" Hose Barb
154-0239



Elbow
3/8" Stem x 3/8" Tube - 154-0258
3/8" Stem x 1/4" Tube - 158-1214



Elbow
1/4" Stem x 1/4" Tube
154-0222



Elbow
1/8" NPT x 3/16" Tube
154-0613



Male Swivel Elbow
1/4" Tube x 1/4" NPT - 153-0818



Compression Fitting
1/4" x 3/8" MPT - 153-0212



Reducing Union
1/4" x 3/16" - 154-0248



Bulkhead Union
3/8" x 3/8" - 154-0285



Union
1/4" x 1/4" - 154-0241



Union Tee
1/4" Tube - 153-0815



Reducing Union
3/8" to 1/4" - 154-0244



Male Connector
1/4" Tube x 1/8" NPT - 154-0224
1/4" x 1/4" MPT - 153-0209



Female Connector
1/4" Tube x 1/8" FPT - 154-0257



Union Tee
3/8" Tube - 154-0815



Oil Fill Stem - PX
3/8" x 3/8" - 153-1055



In-line Coupler
1/8" - 154-0230



Stem Adapter
1/4" NPT x 1/4" Stem
154-0243S



Male Connector
1/2" Tube x 1/2" NPT (Drilled)
154-0232D



Tank Plug
1/4" - 154-0245
3/8" - 153-1054
1/2" - 154-0231



O-Ring for Fitting
1/4" - 154-0287A
3/8" - 154-0287B
1/2" - 154-0287C



Male Luer
1/8" Hose Barb - 154-0863



**Cleaner Tip with
Check Valve**
164-0012M



*Products
&
Parts*
2015-16

www.kegel.net

Toll Free (US Only): 800 - 280 - BOWL (2695)

Fax: 863 - 734 - 0204

International: 863 - 734 - 0200

1951 Longleaf Boulevard
Lake Wales, FL 33859 USA

