

Section F

Pit Conveyor

Index

No.	Part No.	Description
1.	12-300194-000	Jogger Link Assembly
2.	11-125109-001	Hex Nut (1/2-20)
3.	11-198009-001	External Tooth Lockwasher (1/2")
4.	12-300147-000	Washer
5.	12-300071-000	Pulley Assembly
6.	12-300148-000	Spacer
7.	11-430007-000	Bearing (.6693 IDX1.5748 OD)
8.	12-300149-000	Shaft, for machines 27,001 and up - See Note
	12-860641-000	Pulley Arm Shaft Assembly
9.	12-300203-000	Pulley Arm
10.	12-300073-000	Pulley Assembly
11.	11-170009-001	Hex Nut Nylock (5/16-18)
12.	11-190012-001	Flat Washer - SAE (5/16")
13.	11-001270-001	Hex Head Cap Screw (5/16-18 x 1-3/4")
14.	12-400286-000	Spring (for machines so equipped)
15.	11-353208-001	Drive Pin (5/16 x 1-1/4")
16.	11-102220-000	Headless Socket Set Screw
17.	11-125202-001	Hex Jam Nut (5/16-18)
18.	11-421058-000	Flanged Oilite Bearing, for machines prior to 95,224
	11-420054-000	Sleeve Oilite Bearing, for machines prior to 24,000
19.	12-300108-000	Arm & Bearing Assembly
20.	90-675000-000	Black Rubber Pit Mount
21.	11-176001-001	Keps Nut (5/16-18)
22.	12-300024-003	Front Tie Plate
	12-300024-002	Rear Tie Plate
23.	12-300076-000	Front Pier
	12-300077-000	Rear Pier
24.	90-300076-000	Front Pit Mount - Urethane
	90-300077-000	Rear Pit Mount - Urethane
25.	12-300240-000	Torsional Pier Front
	12-300241-000	Rear Mount Assembly
26.	11-001357-001	Hex Head Cap Screw (3/8-16 x 3-1/4")
27.	12-400247-002	Pulley Arm Bushing, Standard (5/8")
28.	12-400247-003	Pulley Arm Bushing, Oversize (7/8")
29.	11-345152-001	Roll Pin (.125 X 3/8)
30.	12-400241-000	Spacer
31.	11-195016-001	Lockwasher (3/8)
32.	11-125104-001	Hex Nut (3/8-16)
33.	11-110130-001	Hex Head Cap Screw (1/4-20 x 3/4")
34.	12-300131-000	Frame Assembly
35.	11-190014-001	Flat Washer (3/8)
36.	11-170012-001	Hex Nut Nylock (3/8-24)
37.	11-001393-001	Hex Head Bolt (3/8-24 x 2-1/4")
38.	12-300160-003	Bearing
39.	11-001506-001	Hex Head Cap Screw (1/2-13 x 1-1/4")
40.	11-170114-000	Flexlock Thin Hex Nut (1/2-13)
41.	12-300141-000	Vibrator Shaft
	12-300126-000	Oscillating Vibrator Shaft - Painted
42.	11-345318-000	Roll Pin (3/16 x 1-3/4)
43.	12-300081-004	Flat Washer

NOTE: For machines prior to 27,001 order 12-860641-000 Shaft Assembly.

Pit Conveyor Drive

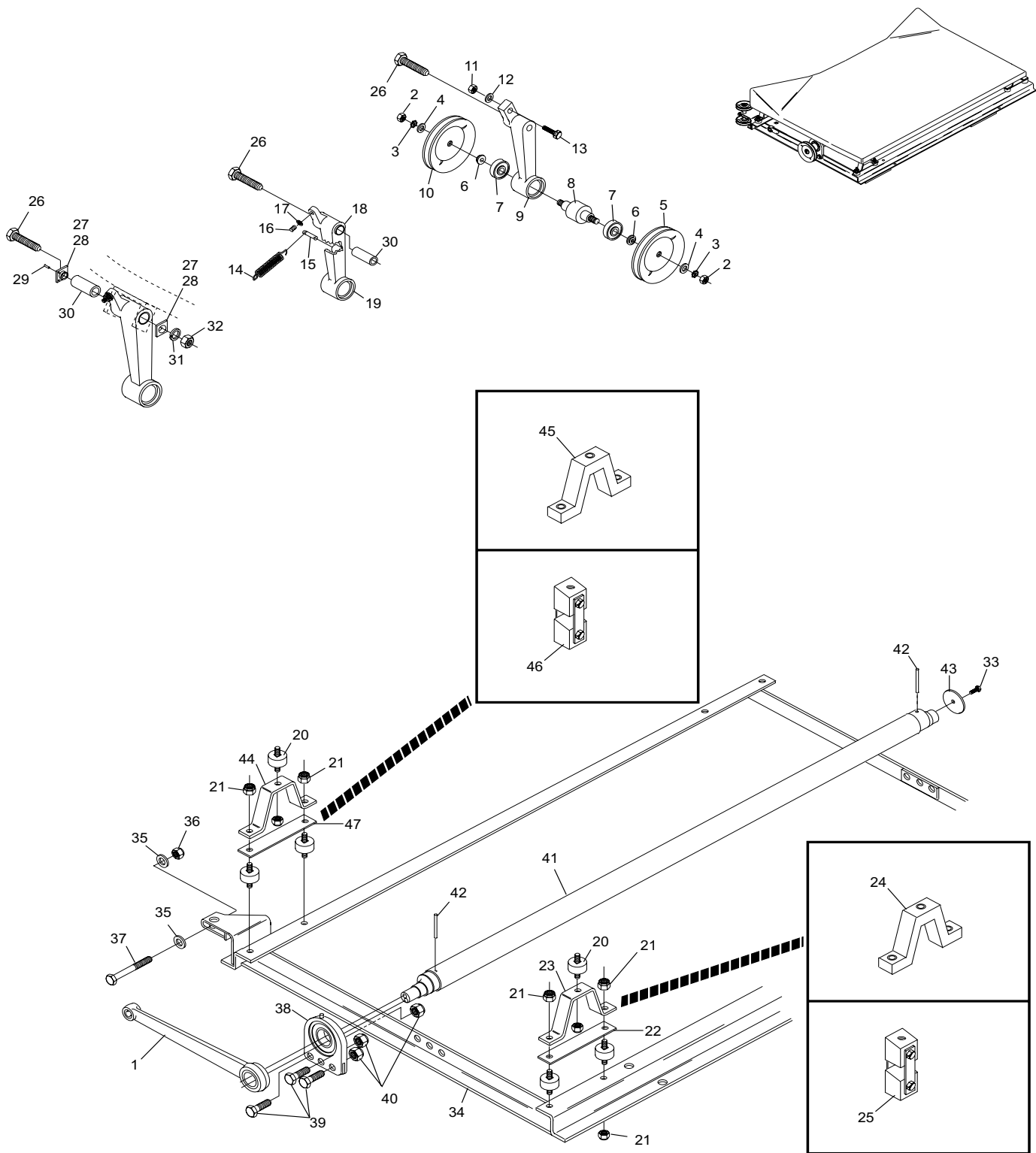

Pit Conveyor Drive

Index

No.	Part No.	Description
1.	11-430016-000	Ball Bearing
2.	11-001184-001	Hex Head Cap Screw (1/4-20 x 1")
3.	12-400033-000	Bearing Retainer
4.	12-300160-000	Bearing & Housing Assembly
5.	11-450001-000	Bearing
6.	11-450201-000	Inner Ring
7.	11-491000-000	Ball Bearing
8.	11-536026-000	Internal Spriol Retaining Ring
9.	12-300163-000	Jogger Link
	12-300194-000	Jogger Link Assembly
10.	12-300013-002	Spacer
11.	12-300088-000	Pulley Assembly
12.	11-005184-011	Hex Socket Head Cap Screw with Dri-Lok
13.	11-196012-001	High Collar Lockwasher (1/4)
14.	12-300016-002	Washer
15.	11-280001-000	Grease Fitting (11/32)
16.	12-300075-000	Idler Pulley Assembly
17.	12-300109-000	Shaft
18.	11-190012-001	Flat Washer - SAE (5/16)
19.	11-001286-001	Hex Head Cap Screw (5/16-18 x 5-1/2")
20.	11-434001-000	Bearing (.500 ID X 1.1250 OD)
21.	11-345318-000	Roll Pin (3/16 x 1-3/4)
	11-530038-000	External Retaining Ring (.992 I.D.)
22.	12-300141-000	Vibrator Shaft
23.	12-300081-004	Flat Washer
24.	11-110130-001	Hex Head Cap Screw (1/4-20 x 3/4")
25.	11-195015-001	Lockwasher (5/16)
26.	11-125100-001	Hex Nut (1/4-20)
27.	11-195014-001	Lockwasher (1/4)
28.	11-125102-001	Hex Nut (5/16-18)

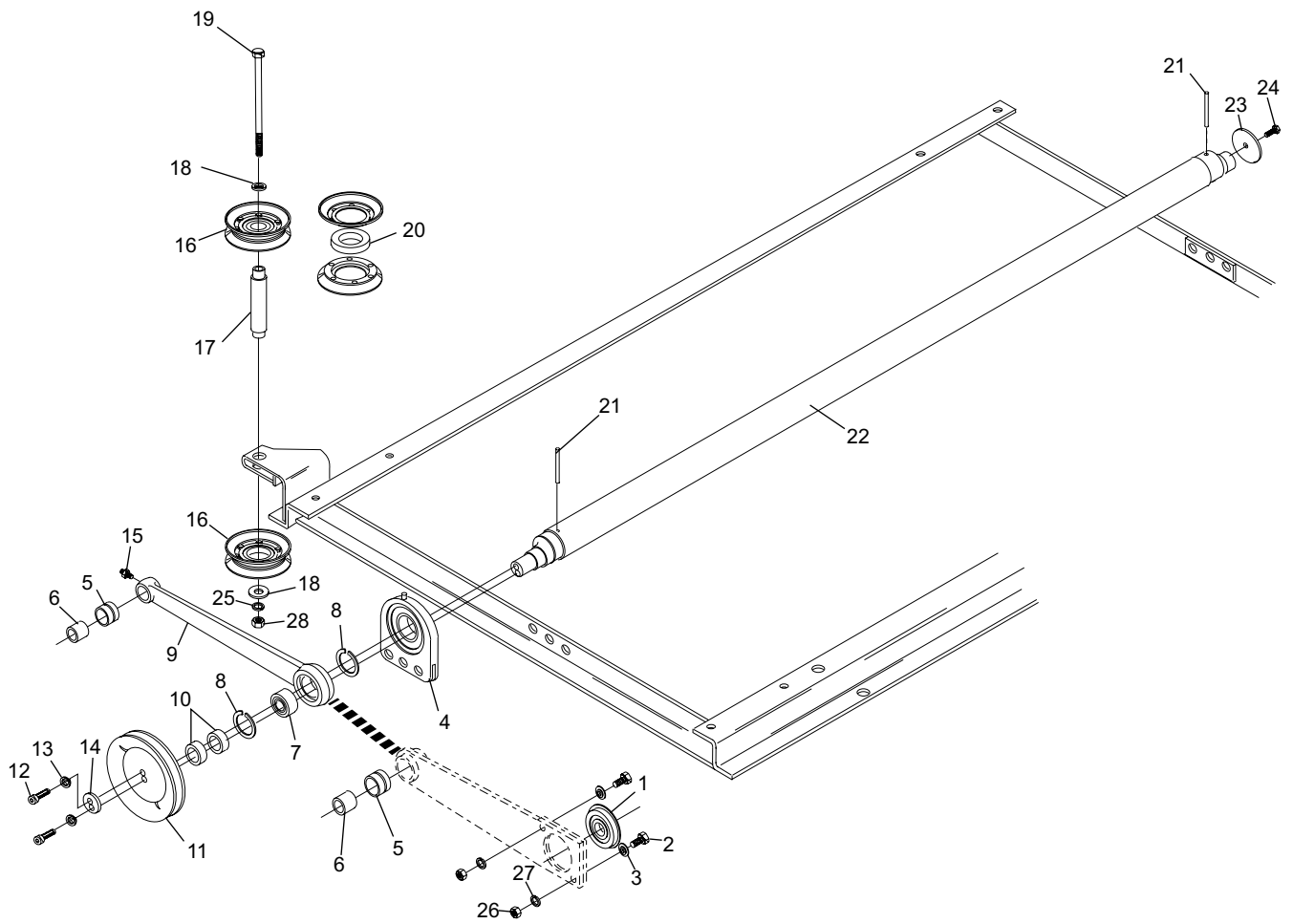
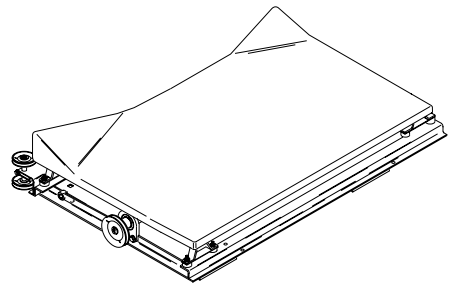

Pit Conveyor Drive

Index

No.	Part No.	Description
1.	11-170013-001	Self-Locking Nut (7/16-14)
2.	12-300110-000	Pit Sub Mounting Plate
3.	11-191018-001	Flat Washer (1/2)
4.	12-300107-002	Carriage Bolt, for machines prior to serial #3850
5.	12-300107-003	Bolt, for machines serial #3850 and up
6.	11-191024-001	Flat Washer (3/4)
7.	11-170016-001	Hex Nut Nylock (1/2-20)
8.	12-860659-000	Pit Frame Assembly
9.	12-300088-000	Pulley Assembly
10.	12-300194-000	Jogger Link Assembly
11.	12-300160-000	Bearing & House Assembly
	12-300160-003	Bearing
12.	12-860725-000	Pit Carpet Cover (1 Ea.)
13.	12-300103-000	Pit Rug
14.	12-860620-002	Fiberglass Pit Board Only
	12-860620-003	Fiberglass Pit Board Assembly
15.	12-300141-000	Vibrator Shaft
16.	12-300131-000	Frame Assembly
17.	11-176001-001	Keps Nut (5/16-18")
18.	11-155401-002	Spline Nut (3/8-24)
19.	11-001390-001	Hex Head Cap Screw (3/8-24 x 1-3/4)

Pit Conveyor Assembly

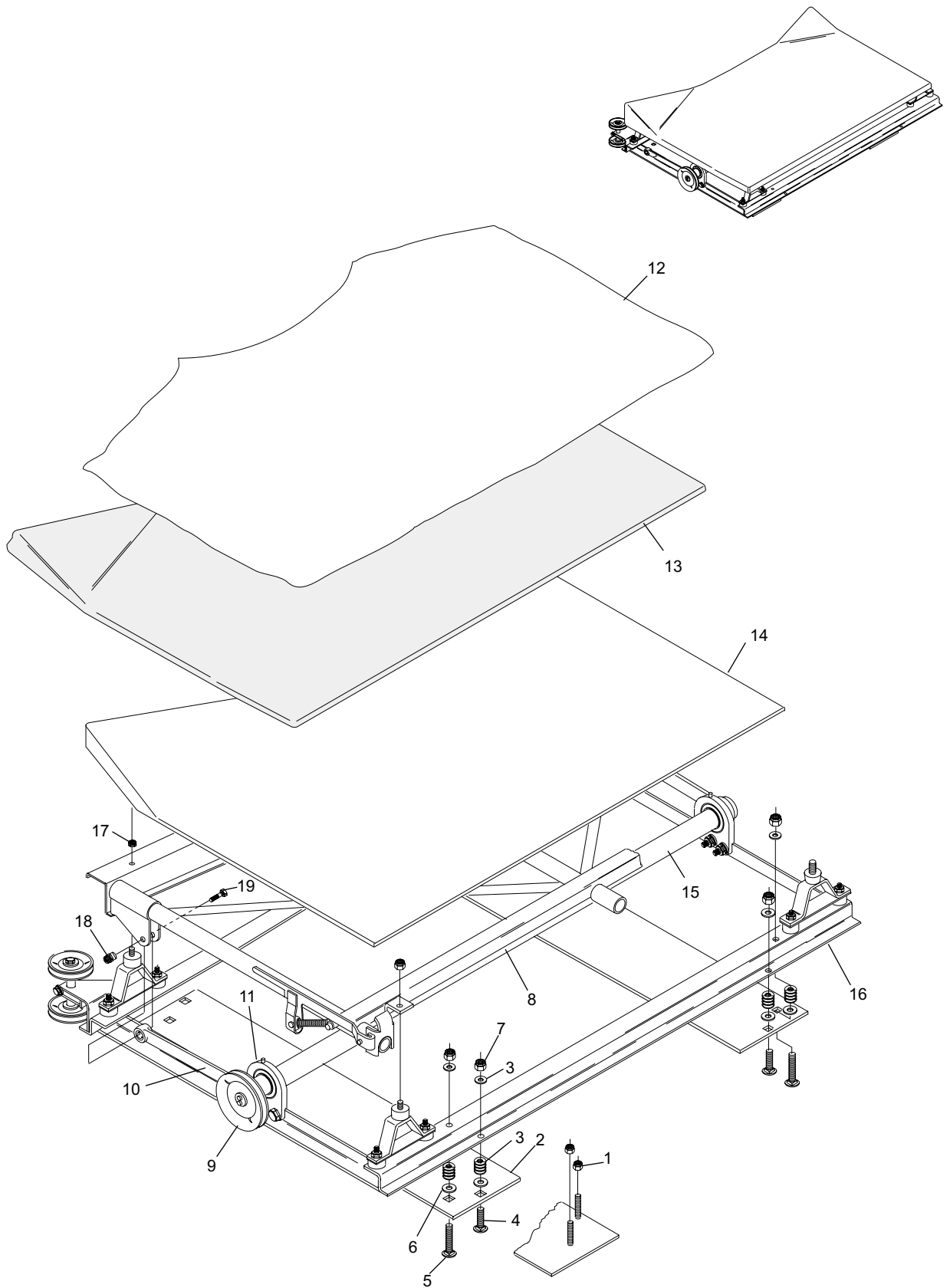

Pit Conveyor Assembly

Index

No.	Part No.	Description
1.	12-300212-000	Rubber Block & Bracket
2.	12-300180-000	Rubber Strip
3.	12-300146-002	Rubber Strip (46")
4.	11-014090-009	Flat Head Socket Cap Screw
5.	11-170005-001	Hex Nut Nylock (#10-24)
6.	12-300146-004	Rubber Strip (17")
7.	12-300103-000	Pit Rug
8.	12-860620-004	Wood Pit Board Assembly
	12-860620-005	Wood Pit Board Only (1/2" 7 Ply)
9.	12-300205-002	Rubber Block (3" x 1-1/2" x 5/8")
	12-300205-003	Rubber Block (3" x 1-1/2" x 1/4")
10.	12-300162-000	Impact Cushion
11.	12-300093-002	Elevator Bolt
	12-300093-004	Elevator Bolt
	12-300093-005	Elevator Bolt
12.	11-190012-001	Flat Washer - SAE (5/16)
	11-190014-001	Flat Washer (3/8)
13.	11-170009-001	Hex Nut Nylock (5/16-18)
	11-170110-001	Hex Nut Flexlock (3/8-16)
14.	12-300207-000	L.H. Deflector Assembly
	12-300208-000	R.H. Deflector Assembly
15.	12-300093-003	Bolt
16.	N.A.	Screw Nail 3/4"
	N.A.	Screw Nail 7/8"
	N.A.	Screw Nail 1-1/4"
	N.A.	Screw Nail 5/8"

Pit Conveyor Boards

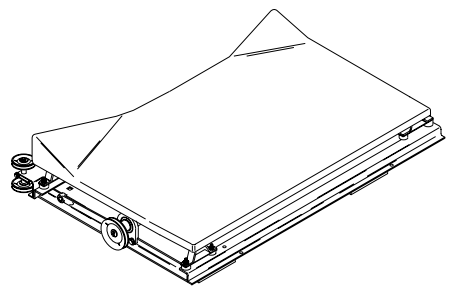
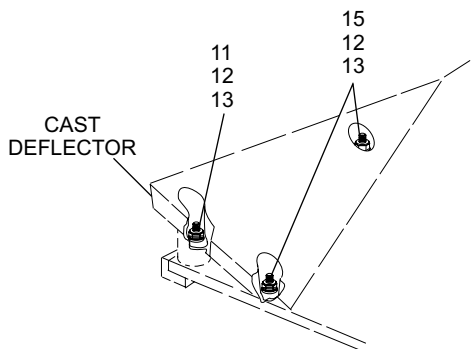

WOOD

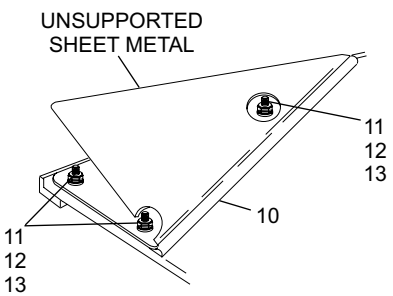
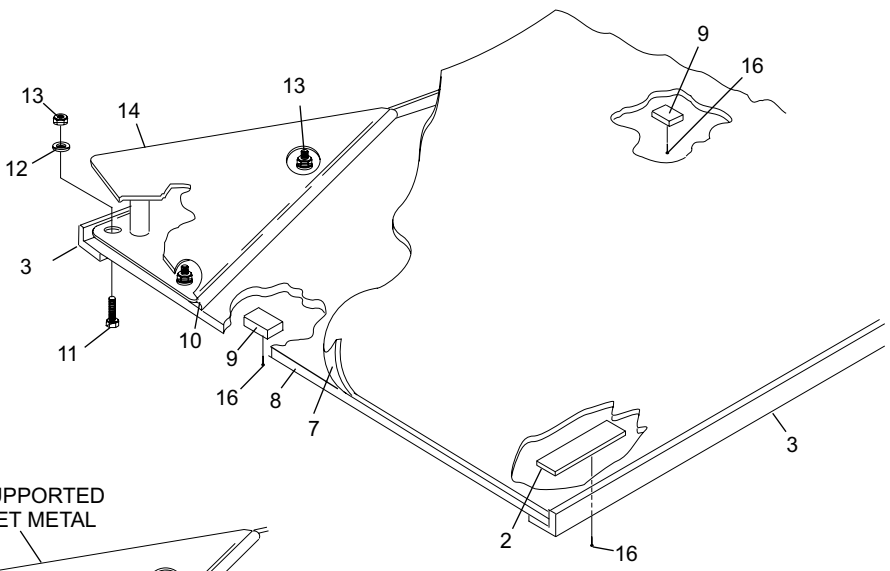

FIBERGLASS

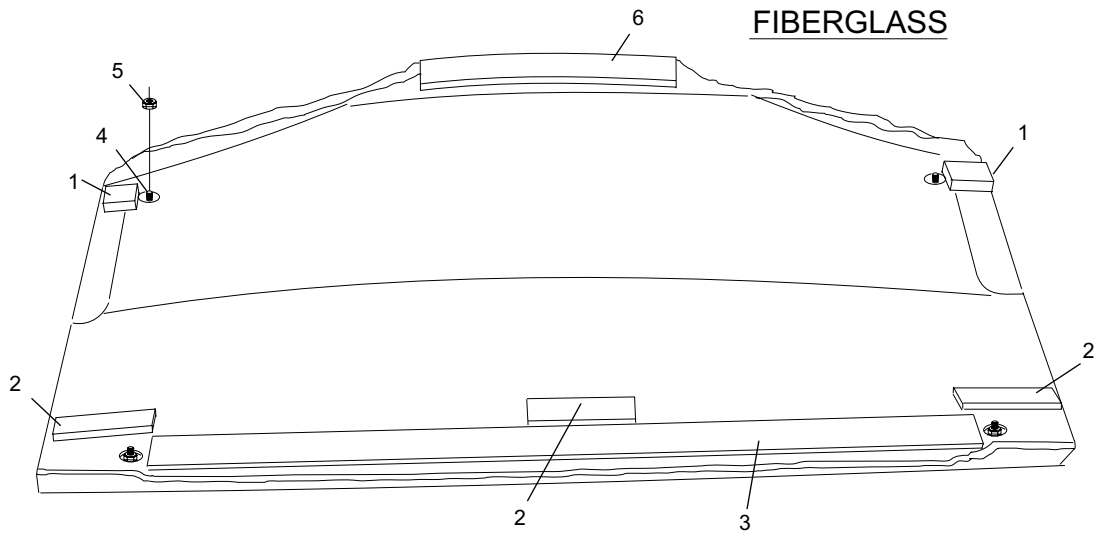

Pit Conveyor Boards

Index

No.	Part No.	Description
1	11-345160-000	Roll Pin (.125 x 3/8)
2.	11-001508-001	Hex Head Cap Screw (1/2-13 x 1-1/2")
3.	11-195018-001	Lockwasher (1/2)
4.	11-190018-001	Flat Washer (1/2)
5.	11-190006-001	Flat Washer - SAE (#10)
6.	11-195010-001	Lockwasher (#10)
7.	11-125004-001	Hex Nut (#10-24)
8.	11-007092-001	Flat Head Socket Cap Screw (10-24 x 3/4")
9.	12-300224-000	Pivot Post
10.	11-345573-000	Roll Pin (1/2 x 2-3/4)
11.	12-300170-000	Spring Guide
12.	11-345258-001	Roll Pin (5/32 x 3/4)
13.	11-190016-001	Flat Washer (7/16)
14.	12-300172-000	Compression Spring
15.	12-300189-000	Step Washer
16.	12-300178-000	Pivot
17.	12-300192-000	R.H. Lever & Bracket
	12-300193-000	L.H. Lever & Bracket
18.	12-300131-000	Frame Assembly
19.	12-860659-000	Pit Frame Assembly
20.	12-302212-000	Pit Board Bumper
21.	12-300168-000	R.H. Clamp & Pin Assembly
	12-300169-000	L.H. Clamp & Pin Assembly
22.	11-191018-001	Flat Washer (1/2)
23.	12-860624-000	Rear Pit Frame Conversion Kit
24.	12-300104-000	Hex Head Socket Cap Screw

Pit Conveyor Frame

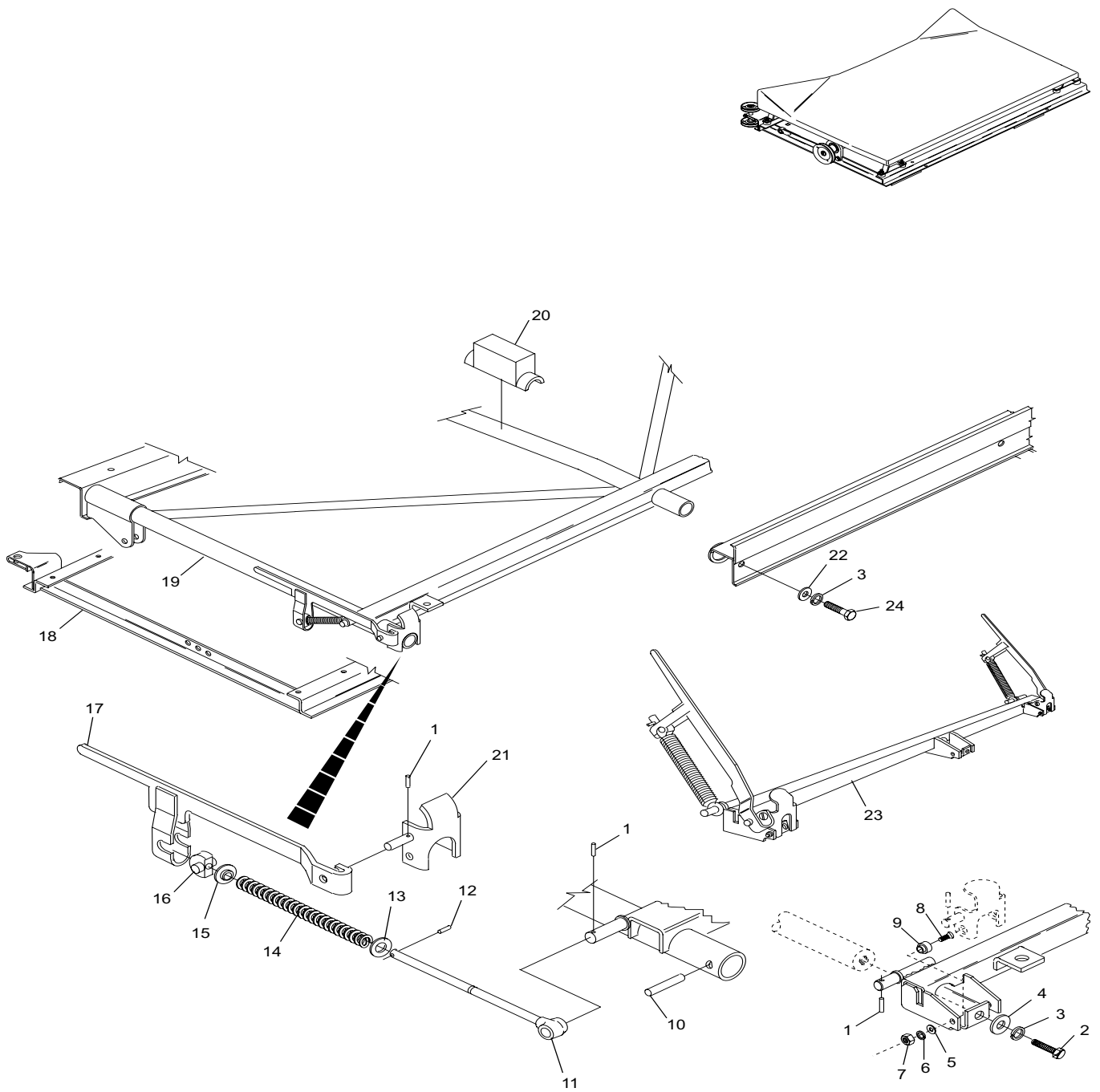

Pit Conveyor Frame