



CENTER MAINTENANCE AND RESURFACING

TRUSTED PRODUCTS SINCE 1890

Brunswick[®]
Experience is Everything.

FEATURED PRODUCTS

Authority22® Lane Machine
See page 15



Brunswick's Envoy and Authority22 lane machines, featuring our innovative Direct+ conditioning system, makes lane maintenance simple and intuitive. The complexity is in the technology, the simplicity is in the operation.

The Phoenix LT4 is easy to operate and maintain. A perfect fit for smaller recreational centers.

Envoy™ Lane Machine
See page 14

Max10 Lane Cleaner
See page 6



DEFYv30™
Lane Conditioner
See page 4



BLITZ
Lane Cleaner
See page 6



Phoenix® LT4
Lane Machine
See page 15



Pins
See page 3



Premium Rental Shoes
See page 2

GREAT SHOT

Struggling to maintain a consistent, high-scoring lane condition that keeps your bowlers happy?
Utilize Brunswick's complimentary "Great Shot" service. For more information visit our website at Brunswickbowling.com.

HAPPIER BOWLERS = BIGGER REVENUE

TABLE OF CONTENTS

BOWLING CENTER SUPPLIES

RENTAL SHOES AND HOUSE BALLS	2
PINS	3
LANE CONDITIONERS	4
LANE CLEANERS	6
LANE CLOTH AND DUSTING SUPPLIES	7
MAINTENANCE SUPPLIES	9
BALL CARTS & BALL RAMP	11
LANE MONITOR SYSTEM	12
BALL PLUG	13

LANE MACHINES

ENVOY™	14
AUTHORITY22® AND PHOENIX® LT4	15
TOP MOVING LANE MACHINE PARTS	16

RESURFACING PRODUCTS

LANE FINISH	18
FINISH APPLICATORS	20
BANKSHOT™ BUMPER BOWLING	22
GUARDIAN®	23
RESURFACING SUPPLIES	23
REPLACEMENT LANE PANELS	25
LANE PARTS	26

RENTAL SHOES AND HOUSE BALLS



MyBall™ System

R8-010059-000 - Fitting Ball and Display Stand

Make selecting a good-fitting house ball easier for your customers with the MyBall System from Brunswick. Our color-coded system and MyFit sizing ball allow customers to easily identify which ball will work best for them, improving bowler satisfaction.

- System includes the MyFit sizing ball with counter display
- Easy identification of hole size and weight. Speeds up the selection process – more time for bowling
- With the MyFit sizing ball, customers select from seven hole drilling sizes (XXS-XXL), then look for their preferred ball weight (6-15 pounds) with the selected hole size

House Balls

60-105544-9XX Undrilled
60-105544-XXX Drilled

Liven up your center with Brunswick house balls. These bright, glow-in-the-dark bowling balls add color and excitement to any bowling environment. They are a great value and carry a two-year warranty; one year for 6-pound balls.

- New formulation Brunswick house balls radiate with light for the ultimate glow-in-the-dark bowling experience!
- Urethane balls available in 6 through 15 lbs
- Strong enough to withstand young or unskilled bowlers
- Available in seven drilling sizes as part of the MyBall System



6# - Lime Green Pearl Glow

7# - Fuchsia Pearl Glow

8# - Sky Blue Pearl Glow

9# - Violet Pearl Glow

10# - Orange Pearl Glow

11# - Purple Pearl Glow

12# - Red Pearl Glow

13# - Yellow Pearl Glow

14# - Kelly Green Pearl Glow

15# - Dark Blue Pearl Glow

Billiard House Balls

60-105507-XXX Billiard Ball

Brunswick billiard house balls, are ideal for boutiques, clubs, and themed centers.



Stripes and Solids match standard billiards set. Weights from 6-15 pounds.



Premium Rental Shoes

58-109114-XXX Lace

58-109116-XXX Hook-N-Loop

If only everything returned its investment as fast and as many times over as Brunswick Premium Rental Shoes. Featuring genuine full-grain leather uppers, foam-padded sock liners,

channel stitching, and rubber heels, these shoes are built to last game after game.

- Hook-n-loop closures
- Glow laces
- Reinforced stitching
- Premium, full-grain leather upper
- Leather sole with channel stitching



Hybrid Rental Shoes

58-109305-XXX Adult Lace

58-109306-XXX Adult Hook-N-Loop

58-109304-XXX Youth Hook-N-Loop

- New contemporary look
- Full grain leather soles with recessed stitching
- Double stitched synthetic uppers
- Padded insoles & Air grommets
- Lace pairs come with extra laces



Youth Rental Shoes

58-109115-XXX

- Full-grain leather uppers and lining
- Leather sole with channel stitching
- Hook-n-loop closure
- Eyelets on inside of arch for airflow
- Colors coordinate with Premium rental shoes.



Value Sport Shoes

58-109302-XXX Youth Lace

(Sizes 3.5-7 – EU sizes 24-32)

Half sizes beginning at size 1)

58-109303-XXX Adult Lace

(Sizes Men 4-16, Women 5.5-12.5, EU 36-50)

- Synthetic upper for long life
- Leather sole and rubber heel pad
- Enamel-covered eyelets for added strength
- Eyelets on inside of arch for airflow



Score King® Pins

- 63-861179-167 Crowns
- 63-861180-167 Crowns – Glow Graphics
- 63-861181-167 Stripes
- 63-861182-167 Stripes – Glow Graphics

Surlyn coating

All Brunswick pins feature a durable Surlyn® coating. Surlyn is a high-performance resin known for its outstanding resilience and impact toughness.

Surlyn is the same cover material used for high-performance quality golf balls.



MAX Colored Pins

- 63-861137-167 Green
- 63-861139-167 Orange
- 63-861138-167 Yellow
- 63-861161-167 Magenta

Let the good times roll with these fun and colorful Max pins. Change out the front pin or the whole set for a new twist on the game or to award prizes. Available in four vibrant, solid colors. Available in single-color sets of ten or individually.



Max Pins

- 63-861167-167 Crowns
- 63-861165-167 Crowns – Glow Graphics
- 63-861168-167 Stripes
- 63-861166-167 Stripes – Glow Graphics

Glow-in-the-dark Pins

Our Score King and Max pins feature UV brightener for ultra-white glow under standard lighting; brighter under UV conditions. Pins with glow graphics have an enhanced logo for extra glow under UV conditions.



Happy Birthday Pins

- 62-861092-167 Happy Birthday

Help your bowlers celebrate their birthdays with this special-occasion pin featuring the crown graphic as well as a “Happy Birthday” message. The Happy Birthday Pin is a Surlyn-coated maple wood pin that can be used for signatures, too. Available in sets of ten or individually.



Trophy Pins

- 63-861157-167 Sets
- 63-861157-000 Singles

Perfect for special occasions to help your bowlers remember a significant score or event, our Trophy Pin is made of maple wood covered in a clear topcoat. It can be used as a signature pin for birthday parties or other special events. Available in sets of ten or individually.

Brunswick Max and Score King Pins give bowlers the high-scoring action they want and the features you need for maximum durability.

- Multilayer topcoat system keeps pins white and glowing brightly
- Surlyn cover allows for a larger wood core to ensure maximum strength
- Made of the finest northern hard rock maple for maximum durability and pin action
- Score King pins feature a heavy-duty, locked-in black nylon base that looks great. Max pins have a neutral locked-in base that stays in place
- Coated Surlyn cover cleans easily and stays whiter longer
- Score King and Max pins are USBC® approved
- All Brunswick pins are made in the USA
- Choose stripes or crown neck graphics
- Available in sets of ten or individually



Universal Pin Cleaner

- 63-860354-005

Keep pins looking bright and new with this advanced performance cleaner.

- Removes the grime and dirt from pins
- BGreen product – formulated to be readily biodegradable and environmentally friendly
- Can be used with both hand and machine cleaning systems
- “Universal” because it also makes a great general purpose bowling equipment cleaner

LANE CONDITIONERS



New DEFYv30 adds a higher viscosity version of DEFY into Brunswick's performance conditioner line. Developed with the same specialty blend of top grade oils and unique additives used to create DEFY, both conditioners generate unparalleled performance compared to lane conditioners in the market today. The enhanced flow-back characteristic reduces the impact of ball tracks through the heads while minimizing the movement of conditioner down lane to keep the shot more consistent. These workhorse conditioners offer excellent solutions for high lineage centers to keep your bowlers satisfied, providing predictable, stable ball reactions with bowlers making fewer, less drastic line-up adjustments as the conditions change. Original DEFY is a low viscosity, high lubricity conditioner, new DEFYv30 is a medium viscosity and medium lubricity conditioner, both are compatible with any surface or lane machine. Developed to increase bowler satisfaction, DEFY conditioners are ThroBot tested and bowler approved.

DEFYv30™ Lane Conditioner

62-860166-004 (4 Gallons)
62-860166-001 (1 Gallon)

DEFY™ Lane Conditioner

62-860164-004 (4 Gallons)
62-860164-001 (1 Gallon)

- **DEFYv30** (100% solids, 30.0 viscosity)
- **DEFY** (100% solids, 20.0 viscosity)
- Both utilize enhanced flow-back
- Both are durable enough for high lineage
- Both clean easily
- Both are ThroBot approved
- Both are 100% silicone free



Logic™ Lane Conditioner

62-860162-005 (5 Gallons)
62-860162-001 (5 Quart)

Logic Lane Conditioner blends top-grade oils with an enhanced additive package. The result is a low lubricity conditioner with great durability and ball motion on harder, less aggressive surfaces. Brunswick quantified the performance of today's top conditioners through extensive ThroBot™ testing. From this data, the best conditioner attributes were used to develop Logic, resulting in the most predictable conditioner on the market to date.

- 100% solids, 43.0 viscosity
- Durable, and resistant to break down
- Consistent performance
- Versatile enough for use on all lane surfaces
- Blended for top performance on low friction surfaces
- ThroBot™ approved
- Easily removed with any Brunswick lane cleaner
- 100% silicone free

Connect® Lane Conditioner

62-860160-005 (5 Gallons)
62-860160-001 (1 Gallon)

Brunswick Connect Lane Conditioner combines cutting-edge technology with real-world expectations. Connect uses top-grade oils with an enhanced additive package to produce a conditioner with great durability and ball reaction. Connect lane conditioner allows you to run longer patterns without the risk of losing the outside boards.

- 100% solids, 33.0 viscosity
- Durable pattern performance game after game
- Versatile enough for use on all lane surfaces
- Blended for top performance of medium to low friction surfaces
- ThroBot™ approved
- Easily removed with any Brunswick lane cleaner
- 100% silicone free

Authority22® W22 Lane Conditioner

62-860205-005 (5 Gallons)
62-860205-001 (1 Gallon)

Authority22 W22's enhanced additive package combined with a special blend of oils creates an easy to use product with reduced carry down that can be easily removed with normal daily cleaning. This premium performance lane conditioner works great on all lane surfaces and can be used with all lane machine technologies.

- 100% solids, 22.0 viscosity
- Pattern friendly, mechanic friendly
- Versatile enough for use on all lane surfaces
- Blended for top performance on medium to high friction surfaces
- ThroBot™ approved
- Easily removed with any Brunswick lane cleaner
- 100% silicone free

LANE CONDITIONERS



Absolute Control®

62-860143-005 (5 Gallons)

62-860143-001 (1 Gallon)

Absolute Control combines the formulas and ingredients from Absolute HV and Control lane conditioners creating a lane conditioner with durability, flexibility and easy cleaning.

- 100% solids, 19.0 viscosity
- Durable pattern performance game after game
- Easily removed with any Brunswick lane cleaner
- 100% Silicone free



Control® Lane Conditioner

62-860046-005 (5 Gallons)

Control lane conditioners offer long-lasting patterns, reduced carry-down and better ball reaction.

- 100% solids, 35.0 viscosity
- Durable pattern performance game after game
- Easily removed with any Brunswick lane cleaner
- 100% Silicone free



Command® Lane Conditioner

62-860022-005 (5 Gallons)

- 100% solids, 22.5 viscosity
- Cleans easily
- 100% Silicone free

LANE CONDITIONERS: COMPARISON OF PHYSICAL CHARACTERISTICS

CONDITIONER	VISCOSITY	SURFACE TENSION	% SOLIDS	SPECIFIC GRAVITY	WICKING TIME
Brunswick DEFYv30	30.0	26.5	100%	0.875	13:40
Brunswick DEFY	20.0	26.0	100%	0.875	7:30
Brunswick Logic	43.0	25.0	100%	0.876	14:30
Brunswick Connect	33.0	24.5	100%	0.850	13:23
Brunswick Authority22 W22	22.0	24.5	100%	0.853	7:30
Brunswick Absolute Control	19.0	24.0	100%	0.879	7:24
Brunswick Control	35.0	24.5	100%	0.852	13:47
Brunswick Command	22.5	26.1	100%	0.848	7:10

LANE CONDITIONING TIPS

WHAT IF I HAVE TOO MUCH CARRY-DOWN

Decrease the distance of the applied oil in the center of the lane leaving the pattern distance the same. This adjustment increases the buff distance and reduces the oil thickness at the end of the pattern.

WHAT IF I DON'T HAVE ENOUGH HOLD

Hold is created by the length and amount of oil in the "mid-lane" (20-32 ft.). This is done by applying oil in the mid-lane on the reverse pass of most lane machines. Lengthening the reverse application distance creates hold oil which allows the ball to more consistently guide to the breakpoint. With Brunswick's Direct+ Conditioning this can be easily accomplished by adding oil to the required boards in zones that affect the mid lane during the forward run.

WHAT IF MY BACK ENDS ARE TOO STRONG

Lengthen the pattern to "tone" down the ball reaction. Make sure that the conditioner application distance does not change, only the total pattern distance.

WHAT IF THE HEADS HOOK

Two things cause the heads to hook. 1. Not enough oil applied to the head area. 2. The physical condition of the heads. To increase the volume of oil in the heads, slow the machine down on the reverse pass. With Brunswick's Direct+ oil system, during the forward run you can increase the units of oil by board in the head zone(s) to resolve this problem.

WHAT IF I HAVE NO SWING AREA

A lack of swing area can be caused by two things: 1. too much oil applied to the outside boards or 2. "crowned" lane topography. Reduce the amount of oil on the outside boards if there is too much. If topography is the problem, contact your professional lane resurfer.

WHAT IF THE MID-LANE BALL TRACK HOOKS TOO MUCH

The mid-lane ball track can hook if there is not enough oil or if there is too much oil. This can be determined by looking at the pattern settings along with Computer Lane Monitor graphs.

For help with your lane conditions, call 1-800-YES-BOWL, or contact your Brunswick Aftermarket Product Specialist. Contact info at brunswickbowling.com/contact/aftermarket-product-specialists.

LANE CLEANERS



MAX10 Lane Cleaner

62-860239-025 (2.5 Gallons)

MAX10 Lane Cleaner is a heavy-duty concentrated cleaner designed to work with the modern, faster lane cleaning machines. MAX10 Lane Cleaner is highly effective in removing the newer lane conditioners containing high viscosity synthetic mineral oils and performance additives.

- Great value - 2.5 gallon bottle makes 10% more product than traditional 5 gallon buddy pack of 4:1 cleaner
- Superior lane cleaning performance
- Provides strong and consistent backend reaction
- One pass cleaning on even the toughest conditioners
- Non-hazardous for shipping
- Save on freight and storage space
- BGreen cleaner
- For vacuum lane cleaning only



MAX20 Lane Cleaner

62-860239-000 (10 - one-pint)

MAX20, a 20:1 concentrated cleaner, incorporates a unique set of properties that make it ideal for cleaning even the toughest conditioners in a single pass. Since MAX20 is a liquid concentrate it does not need to dissolve and is ready to use when combined with water. Max power in a mini package.

MAX20 comes in a package of 10 one-pint bottles. Each pint makes 2.5 gallons of product. The package is comparable to a 5-gallon buddy pack of 4:1 cleaner.

- Excellent lane cleaning performance
- Provides a strong and consistent backend reaction
- One pass cleaning on even the toughest conditioners
- Non-hazardous for shipping
- Save on freight and storage space
- BGreen cleaner
- For vacuum lane cleaning only



BLITZ Concentrated Lane Cleaner

62-860250-000 (10 - one-pint)

Blitz is an environmental friendly, BGreen 20:1 concentrated lane cleaner that can be used to remove any lane conditioner in a single pass. Just add water and Blitz is ready to use. Blitz requires no dissolving due to it's liquid homogenous formulation. Save freight with the small package that is easy to handle and reduces storage space.

- Effective cleaning
- Economical and Environmentally friendly
- Increases backend reaction to help pin carry
- Reduced shipping costs because of its higher concentration
- BLITZ comes in a package of 10 one-pint bottles. Each package makes 25 gallons of product, which is comparable to a 5-gallon buddy pack of 4:1 cleaner.



Authority22[®] Lane Cleaner

62-860206-005 (5 Gallons)

- Special additive package to clean even the toughest lane conditioners
- Special de-foaming agent for large tanks
- Cleans with one pass
- BGreen cleaner
- Guaranteed performance



Judge[®] Lane Cleaner

62-860066-005 (5 Gallons)

Judge lane cleaner is designed to remove difficult to clean lane conditioners. Formulated with an enhanced additive package to produce Brunswick's strongest cleaner yet. The Judge is a non-hazardous cleaner that can be used with all vacuum lane cleaning equipment.

- Water based lane cleaner
- Designed for difficult to clean conditioners
- Premium performance
- Fresh scent
- BGreen cleaner
- For vacuum lane cleaning only



Invincible[®] Lane Cleaner

62-860055-005 (5 Gallons)
62-860055-030 (30 Gallons)

Designed to clean even the toughest lane conditioners. Formulated to be fast acting for today's newer lane machines. Simply the most effective lane cleaner available today.

- Water based lane cleaner
- Special additive package to clean even the toughest lane conditioners
- Guaranteed performance
- BGreen cleaner
- For vacuum lane cleaning only



No-Spill Mixing Vessel

14-860209-000

- Patented technology
- Controls liquid flow to cleaner tank
- Convenient no-spill container
- Holds 2.5 Gallons of mixed cleaner

Replacement Spout

14-100355-000

Use as a replacement spout for conditioner container or remove coupling and use as a replacement for No-Spill Mixing Vessel spout.



LANE CLOTH AND DUSTING SUPPLIES



8460QC Lane Cleaning Cloth

61-860290-000 (4 Rolls/carton)

8460QC uses the same proven heavy-duty material found in the 8460XL blue cloth but features a quick-change plastic core. This new design will save you time and scrub your lanes clean.

- Saves time
- Easy to use
- Eliminates hassle
- Use with Kegel® wick/pad and pump lane machines 2004 and newer
- 20 yards per roll



8460XL Lane Cleaning Cloth

61-860250-000 (4 Rolls/carton)

8460XL virtually “scrubs” cleaning solution onto the lane with its special fiber cloth.

- Heavyweight cleaning cloth
- Use with Kegel wick/pad and pump lane machines pre 2004
- 18 1/3 yards per roll



Authority22/Envoy™ Duster Cloth

62-860207-000 (4 Rolls/carton)

Authority22/Envoy Duster Cloth cleans the lane before the cleaner is applied. The process uses less cloth and helps the cleaner work directly on the conditioner, not the surface dirt.

- Water-resistant core
- Special fiber maximizes scrubbing action
- Absorbs dirt and cleaner fast
- For use in Brunswick injector lane machines
- 20 yards per roll







Gold Edge Lane Cleaning Cloth

61-860252-000 (4 Rolls per carton)

Gold Edge Cloth is composed of a special mixture of fibers to maximize “scrubbing action” and edge out the competition.

- Quick-absorbing design for fast and complete cleaner pickup
- Specially designed scrubbing weave
- Use with wick/pad and pump lane machines
- 20 yards per roll

LANE CLOTH & DUSTER COMPARISON CHART

LANE MACHINE OR DUSTER TYPE	BRUNSWICK	AMF	CORE/DOWEL	ROLLS PER CARTON	YARDS PER ROLL	CLOTH WIDTH	OVERALL WIDTH
Kegel Machines 2004 & Newer	61-860290-000	N/A	Plastic	4	20	43”	44-3/4”
Kegel Machines Pre 2004	61-860250-000	294008460	 CORE	4	18-1/3	43”	44-3/4”
Authority22/Envoy	62-860207-000	N/A		4	20	43”	44-3/4”
Gold Edge Lane Cleaning Cloth	61-860252-000	N/A	 CORE	4	20	43”	44-3/4”
Brunswick, DBA, Perry-Austen Lane Maid DBA Aluminum Duster DBA Lane Runner	61-860168-000	294008430	 DOWEL 7/8” Diameter	3	33-1/3	43”	44-3/8”
Brunswick Lane Duster All Century Machines PA Champion Century Hot Duster DBA Strip n’ Dust DBA Lane Walker DBA Excel	52-860078-000	294008443	 CORE	4	25	43”	44-3/4”

LANE CLOTH AND DUSTING SUPPLIES



Red Edge® ** Lino-Duster Cloth

61-860168-000
(3 Rolls per carton)
52-860078-000
(4 Rolls per carton)

Red Edge Lino-Duster Cloth contains strong, long fibers that trap and hold dirt improving cleaning performance.

- Removes dirt, while leaving conditioner pattern undisturbed
- Available in two sizes to fit many lane dusters
- 100 yards per box

**See Chart on Page 7.

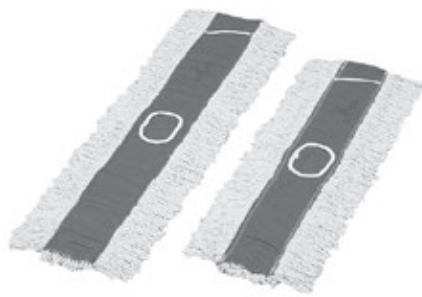

Precision Gutter and Capping Mop Refills

62-860094-000 (Set of two mop heads)

Don't let old, worn mop heads increase work by forcing a need to double run the gutters.

- Replace the old ones with clean, new mop heads
- Same high-quality mop heads as the original
- Heavy-duty reinforced stitching, strong lint-free cotton yarn, and machine washable
- Set comes complete with one larger mop head for ball return caps and gutters and one smaller head for division caps and gutters



Brunswick Lane Maid

61-860158-001

Brunswick's unique design provides the ideal way to get the dust without disturbing the lane condition.

- Aluminum support bar applies even pressure to foam pad and duster cloth for a complete cleaning, regardless of lane conditions
- Cloth contours to any lane and any lane surface
- Automatic action ratchet advances duster cloth with no fuss
- 43" wide duster cleans the entire lane in one pass
- Lightweight for easy maneuvering
- Installing clean duster cloth is a snap

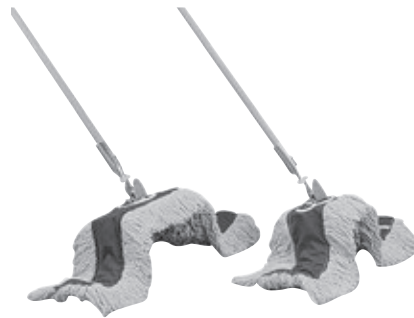

Precision Gutter and Capping Mops

62-860093-000 (Set of two mops)

Cut cleaning time in half by using these convenient mops.

- Specially designed mop head cleans cap and gutters at the same time
- One mop has a larger head for ball return caps and gutters, the smaller mop cleans division caps and gutters
- Package comes complete with one mop of each size
- Mop head made from strong woven yarn that grabs dust from caps and gutters
- Heavy-duty reinforced stitching prevents lint-free yarn from coming loose
- Mop heads are machine washable
- Swivel handle for easy operation

LANE CLEANING AND DUSTING TIPS

- Check the condition of the cleaning pad or cushion roller
- View the lane machine spray pattern
- Be sure spray jets are not clogged
- Inspect the condition and adjustments of squeegee blade(s)
- Are lanes air-drying or is cleaner being removed by your machine?
- Be sure to dust your lanes daily from pin deck to foul lines, prior to cleaning
- Avoid using hard water to mix your cleaner, as hard water reduces a cleaner's effectiveness
- Test your lanes regularly to verify the effectiveness of your cleaning system.
- Verify cleaner supply tank is full before cleaning lanes



Lane Maintenance Applicator

61-860230-000 (Complete applicator)

When cleaning lanes by hand, there's no better tool to use.

- Reinforced handle won't break or bend as you apply pressure
- Grips terry cloth lane towels for heavy-duty lane cleaning
- Replacement Pad (NEW) 61-100272-000

62-860101-000 Channel Mop Complete

62-860103-000 Channel Mop Heavy Duty Refill

MAINTENANCE SUPPLIES



IPA 99 Synthetic Approach Cleaner

61-860254-000
(12 x 1 Quarts with 4 sprayers)
61-860255-000 4 refill bottles
(1 Gallon each)

Synthetic approaches require cleaning with a product that won't leave moisture on the approach surface. IPA 99 effectively "conditions" a synthetic approach after it has been spot cleaned; it also displaces surface moisture as part of a regular synthetic approach maintenance program.

- Convenient 1 quart spray bottles with sprayer
- One gallon refill containers
- Pulls moisture from synthetic approaches
- Not recommended for use on wooden approaches



Approach Treatment

62-860078-001 (4 x 1 Gallons)
Take the stickiness out of approaches.

- Improves slide conditions for sticky approaches
- Provides long-lasting, effective treatment on both wood and synthetic lanes



Automatic Pinsetter Cleaner

62-860083-005 (5 Gallons)
Here's an effective way to degrease and clean metal pinsetter parts.

- Strong, solvent-based cleaner cuts through tough pinsetter grease and grime
- Note: Do not use on nonmetal parts



Approach Dry Slide

62-860210-600 (12 x 11.2 oz Canisters)

Approach Dry Slide is a non-abrasive powder used to eliminate sticky approaches. It can be used on both wood and synthetic approaches and is easy to apply. Offered in convenient 11.2 oz shaker canisters for ease of application.

- Non-abrasive
- Eliminates sticky approaches
- Used on both wood and synthetic approaches
- Best product offered to eliminate sticky approaches



Armor Slide

62-860024-000 (2 Gallons)

Give synthetic approaches better slide characteristics, use Armor Slide.

- General purpose approach aid improves approach performance
- For synthetic approaches only



Brunswick Liquid Friction Pin Deck Treatment

62-860138-000 (2 x 1 Gallons) Plus empty pint spray bottle per carton

Effectively ends out-of-range and sliding pin problems. Also quickly and effectively increases the coefficient of friction of pins decks, promoting falling pins over sliding pin action.

- Easy to use. Just spray and dry
- Works effectively on wood or synthetic pin decks



Approach Spot Cleaner

62-860034-004 (4 x 1 Gallons)

Keep approaches looking clean and spotless.

- Removes dirt and heel marks fast and efficiently
- Solvent-based cleaner dries quickly
- For use on all approach surfaces



Approach Mop

62-860095-000 (Complete mop)
62-860096-000 (Mop head refill)

Keeping approaches clean is essential for optimum sliding conditions.

- 36" wide mop head is ideal for dusting approaches
- Durable cotton yarn head attracts dust and dirt, leaving approaches clean
- Washable and replaceable



Deck Chute Conditioner

62-860029-000 (1 Quart)

Improve the durability and performance of deck chutes. Longer lasting and more stable, this Advanced Performance deck chute conditioner has been designed to minimize deck jams by allowing pins to slide easily through the chutes.

- Improved formula promotes longer chute life
- Durable and more stable
- Minimizes deck jams and downtime

MAINTENANCE SUPPLIES



Command Network™ Team Scoring Recap Forms

57-860422-000 (4-part form/package of 750)

- Use this special NCRTM paper in Command Network printers
- Distribute forms to team captains, league secretaries, offices/managers, newspapers, or others who could benefit from the scores



Printer Paper for Command Network Receipts

57-860412-000

Always hand customers a receipt for their purchases.

- One 90' roll of white receipt paper



Source Power Printer Paper

67-860251-000

This paper is ideal for printing league records, bowler information, accounting ledgers, and more.

- 8-1/2" wide white paper for use in your Source Power Printer
- Tractor feeds are perforated for easy removal
- Package of 3,400 sheets



Sani-Spray Shoe Sanitizer

61-860062-000 (12 x 15 oz. cans)

Strike rental shoe odor dead with power to spare.

- Clean, fresh scent to please customers
- Keeps front desk storage area odor free for a pleasant work environment
- One 15-ounce can sanitizes approximately 300 pairs of shoes



Aero-San Shoe Deodorizer

190170 (12 x 12 oz. cans)

- Completely deodorizes and sanitizes rental shoes
- Each can freshens approx. 500 pairs of shoes



Aerosol Approach Spotter

130190 (12 x 13.5 oz. cans)

- Easy to use
- Great for quick spot cleaning



Tile-Lastic Waxless Floor Coating

1905611 (4 x 1 Gallons)

- Contains no wax. Easy to apply. Dries quickly
- Needs no buffing or polishing
- Can be used on all types of floors



Factory Finish Buffing Compound

14-800009-000 (2 compound blocks per pkg.)

Utilizes the same ball polish products as our manufacturer. Helps restore your ball to its out of the box look. Factory Finish can be used with plastic, urethane or performance balls.

- Fits Ballworx, LustreKLEEN, and Lustre King ball polishing machines
- Factory finish gloss for all balls
- Replaces Brunswick Lustre Sheen, LustreKLEEN and DBA Blue Genie compounds



Grey Automatic Pinsetter Paint

62-860062-000 (One 12 oz. can)

Keep the pinsetter looking as good as new. Fix nicks, scratches and scrapes quickly and easily.

- This is the original grey paint used on the automatic pinsetter
- Convenient spray paint dries quickly to a durable finish
- Available in a 12-ounce aerosol can

Cosmic® Fog Fluid

62-860112-004 (4 x 1 Gallons)

Brunswick Cosmic fog fluid is a water based formulation created to be used as a special effect for open bowling or special events.

BALL CARTS & BALL RAMP



BALL CARTS AND BALL RAMP COLOR OPTIONS

COLOR	SUFFIX*
BLACK	000
SILVER	004
GREEN**	001
YELLOW**	002
BLUE**	003

**Special Order – 8 week lead time

Ball Carts

62-860311-XXX* (Two Tier)

62-860312-XXX* (Three Tier)

These durable and attractive ball carts enable you to easily transport house balls across the center as needed. Available in different colors. See color chart.

Ball Ramp

62-860310-XXX*

The Ball Ramp enhances the bowling experience for younger bowlers, or those with special needs, making bowling more fun and bringing them back again and again. Available in different colors. See color chart.

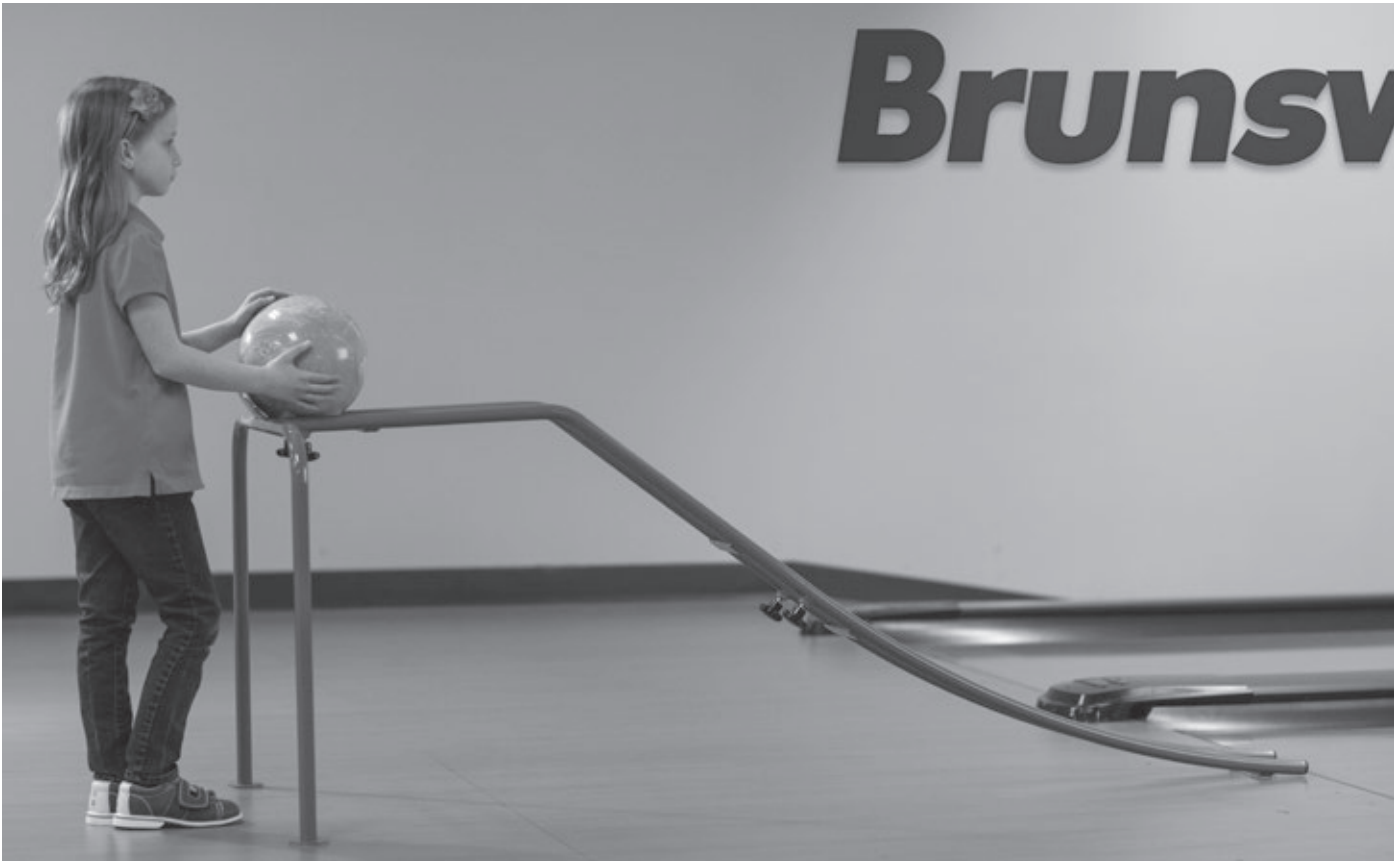

LANE MONITOR SYSTEM

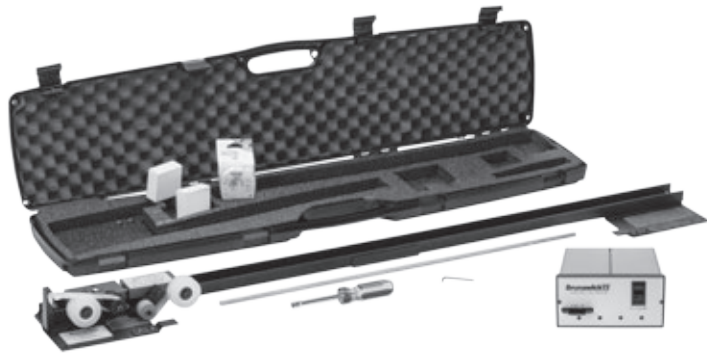

Computer Lane Monitor System™

61-860226-600 (110 V)
61-860226-620 (220 V)

Computer Lane Monitor System reduces maintenance time and human error. Includes:

61-100057-000 (White Label Tape)
11-900070-000 (UV Pick-Up Tape)
61-860162-000 (Calibration Kit)
61-860155-000 (Lane Recorder)
61-860225-600 (Computer Lane Reader, 110V)
61-860225-620 (Computer Lane Reader, 220V)

- System includes all components of Computer Lane Monitor Optical Reader, Lane Monitor Recorder, Calibration Kit, UV Pick-Up Tape and White Marking Tape
- Based on the computerized Optical Reader, this system takes the guesswork out of reading tapes and provides immediate, accurate feedback
- Windows® software provides more detailed analysis including 3-D graphics (IBM® compatibility required)
- Measure newly conditioned lanes as well as changes in lane conditions, such as oil depletion and carry-down
- Keep bowlers satisfied by ensuring that lane conditions are the same from lane to lane and week to week
- Verify lanes are in compliance with USBC®/WIBC and FIQ conditioning rules
- The lane monitor system requires use of a lane conditioner containing USBC/WIBC specified UV additive



Computer Lane Monitor Optical Reader

61-860225-600 (110 V)
61-860225-620 (220 V)

An industry standard since 1988, the Brunswick Lane Monitor provides the ultimate in accuracy and reliability for measuring and graphing lane conditioner volume and distribution.

- Higher resolution for improved accuracy
- Increased range accommodates higher conditioner volumes
- Addition of USB port provides compatibility with new PCs
- User-friendly software
- Holds higher graph scales
- High capacity tapes are conveniently read from end to end



Lane Monitor Recorder

61-860155-000

The original Lane Monitor Recorder is still the best.

- Two sliding tape carriages in an aluminum track are placed on the lane from gutter to gutter
- One carriage applies the transparent tape to the lane surface to absorb the dressing
- The second carriage lifts the dressing tape and laminates to a second tape, locking the dressing between the two, creating a permanent, accurate sample of the conditioner pattern
- Comes complete with all recorder components, recorder tape, label tape, assembly tool and instructions in a sturdy case

White Marking Tape

61-100057-000



UV Pick-Up Tape

11-900070-000



Tape Hub

61-100055-003

Rubber Wheel Assembly

61-100055-004

Foot Pad Small

61-100055-016

Foot Pad Large

61-100055-018

Roll Pin (1/8" x 1/2")

11-345154-000

Computer Lane Monitor Software

61-860273-400 CD V1-01
61-860273-401 CD V2.00



Rubber Roller

61-100261-000



Calibration Kit

61-860162-000

- Package of three strips
- It is recommended to replace calibration strips after one year



UV Bulb

61-100060-000

321 Color Kit

160321CK Color Kit complete (Each)

- Complete color assortment of nine different pigments.
- One ounce size.

INDIVIDUAL COLORS:	
160321BLU	Blue
160321RED	Red
160321YEL	Yellow
160321BLK	Black
160321GRN	Green
160321PUR	Purple
160321SLV	Silver Pearl
160321GLD	Gold Pearl
160321WHT	White



321 Ultima™ Pro-Plug®

160321UPP Clear 2 Gallon Kit
(3 x 1/2 Gallons Clear Compound)
(1 x 1/2 Gallon Hardener)

- Can be used in all bowling balls: rubber, polyester, urethane or resin
- Unique curing process accelerates initial reaction, then slows to a stable cure
- Plug resists cracking, chipping due to high-temperature cures

Ultima™ Pro-Plug® Accessories

160321PK Pro-Plug Calibrated Pump Set:
fits 1/2 gallon (1 Hardener, 1 Compound)

160321F Oval Finger Plug Dams (100 per box)

160321T Round Thumb Plug Dams (100 per box)

160321SS Stir Sticks (500 per box)

160321GC Granulated Mixing Cups (50-5 oz. cups)

160323 - Pro-Plug Cube Trays (Each)

Ball Plug Tips

1. Mix plug thoroughly for specified time before pouring into hole
2. Pour slowly down sides of the hole or over a stir stick to avoid entrapment of bubbles
3. Temperature of the plug, the bowling ball and the work environment **MUST** be between 68° and 72°F for a thorough cure
4. Match colors in the compound before adding the hardener. This will allow extra matching time and eliminate over mixing of the plug material
5. Measure compound and hardener accurately
6. Use Cube Trays to eliminate plug waste



LANE MACHINES



Envoy™ Lane Machine

- R8-040000-001 - Envoy with AGM Battery and ACDC Power Supply (115V)
- R8-040000-201 - Envoy with AGM Battery and ACDC Power Supply (230V)
- R8-040000-002 - Envoy with Lithium Battery and ACDC Power Supply (115V)
- R8-040000-202 - Envoy with Lithium Battery and ACDC Power Supply (230V)

Since the introduction of the B90 oiling machine in 1962, Brunswick has been a leader and an innovator in automatic lane maintenance systems. And we've learned a lot along the way. The Envoy, our newest lane machine, is a state-of-the-art cordless system centered around your needs.

- Direct+ conditioning, with its direct-to-lane conditioner application, takes away the variation that comes with transfer system machines
- Despite its sophistication, the six-button Graphical User Interface makes the Envoy simple to program and easy to operate
- Envoy's cleaning system, featuring a unique V-shaped squeegee, assures your lanes are thoroughly clean so the shot is consistent
- FlexPower gives you the option of running on AC or two different types of battery power, whatever your center needs
- The Envoy is easy to operate, only requires five minutes of daily maintenance and comes with a two-year warranty





Authority22® Lane Machine

R8-030000-000 (115V)

R8-030003-000 (230V)

The Authority22 Lane Maintenance System by Brunswick addresses industry challenges by combining advanced technologies with Brunswick's unparalleled understanding of the lane maintenance needs of bowling centers.

- Direct+ conditioning system assures accurate and consistent conditions with its direct-to-lane conditioner application
- Accu-ject® innovation allows precise direct application of lane conditioner to the lane surface, board by board
- Allows for simpler, faster and more predictable pattern development
- Eliminates wicks and smoothing pads
- Blends the conditioner for smoother pattern transition with the buffer brush

Phoenix® LT4 Lane Machine

R8-010061-000 (110V 60 Hz)

R8-010062-000 (220-230V 50Hz)

The Phoenix LT4 is an affordable lane machine designed specifically for centers 16 lanes or less. New features have been added to enhance this easy to operate combination machine which cleans, oils and buffs in a single pass. The Phoenix LT4 is an efficient and affordable solution for your small center's lane maintenance needs. Enjoy the simplicity of operating a LT4.

- Clean and condition a 16 lane center without stopping to refill cleaner and conditioner tanks or emptying the waste tank
- Easy to use so that "anyone" can program or operate the Phoenix LT4 with little or no instruction
- New 4 pattern option provides both open and competitive bowling conditions
- Simple and intuitive operation allows for quick training



Brunswick Pattern Manager Software

14-860027-000

Brunswick Pattern Manager is a program developed specifically for Direct+ conditioning technology users. The Brunswick Pattern Manager allows you to easily download patterns from the Brunswick Pattern Zone and transfer them to your Envoy or Authority22 lane machine.

Brunswick Pattern Editor Software

14-860028-000

The Pattern Editor is a plug and play software that allows you to edit and/or create your own patterns. This add on software to the Pattern Manager helps you build your own library of patterns to meet the needs of your bowlers.

TOP MOVING LANE MACHINE PARTS

ENVOY™

PART NUMBER	DESCRIPTION
11-005266-015	Screw 5/16-18 x 1 1/4 Hex Hd Skt Rohs
11-005514-015	Screw - 1/2-13 x 2-1/2" Lg. Socket
11-006063-000	Screw - 8-32 x 1/2 Lg Button Hd Cap
11-006073-015	Screw -#8-32 x 1-1/4 Lg, Button Head
11-006120-015	Screw - #10-32 X 5/8" Lg
11-007777-000	Screw -1/4-20 x 1-1/8 Lg, Flat Head
11-054301-015	Hitch Pin - 62mm Lg
11-171505-015	Nut - 1/2-13 Hex Serrated Flange
11-190006-015	Washer #10 Plain SAE Std
11-190554-015	Washer - 11/64 ID x .75 OD Fender
11-192577-000	Shim .376 ID x .563 OD x .010 Thk
11-210007-000	Bracket - 10mm Ball Pem, Gas Spring
11-491104-000	Sprocket - 23 Tooth, 3/8 Bore
11-601013-000	Roller Chain
11-615189-000	Switch - Rocker, Dpst On-Off Vac
11-655070-000	Spray Tip - 110 Deg, .05 GPM, S.S.
11-655073-000	Gearbelt-1/2 Wide x 3/8 Ptch x 28.5" Lg
11-655074-000	Nozzle Body -Female, 1/4 x 11/16-16
11-655077-000	Cuff 1-1/2" Male/Female Wire Spt Hos
11-655078-002	Hose - 1-1/2" X 27" Wire Sppt PVC
11-655080-000	Fitting - Tee, 3/8 Tube to 1/4 NPT
11-655086-000	Strainer - 100 Mesh Screen
11-655087-000	Union - Y, 3/8 Dia. Tube
11-672528-000	Relay - Power, T9A
11-680045-000	LED - Panel Mount, Red 12V
11-680046-000	LED - Panel Mount, Green 12V
11-685134-000	Fuse - 40 Amp Maxi Fuse
11-696006-000	Circuit Breaker -Thermal 25 Amp
14-100364-000	Assy - Friction Clutch
14-100406-000	Assy - Line Strainer, Cleaning Systm
14-100472-000	Decal - Daily Maintenance
14-100724-005	Assy. - 24VDC Duster Gearmotor, 5 RPM
14-100724-022	Assy. - 24VDC Squeegee Gearmotor, 22 RPM
14-100724-050	Assy. - 24VDC Dispersion Roller Grmtr, 50 RPM
14-100725-000	Assy - 24VDC Solenoid Valve w/ Conn

ENVOY

PART NUMBER	DESCRIPTION
14-100730-000	Bracket - Caster
14-100731-000	Mount - 6" Wheel
14-100732-000	Assy -6" Dia. Wheel, Lane Machine
14-100747-000	Pulley-Gear, 24 Teeth 3/8 Ptch 12" Bt
14-100755-091	Assy - Conditioning Pump w/ Fittings
14-100758-091	Assy - 24VDC Cleaner Pump w/ Fittngs
14-100766-000	Assy-Traction Drive Motor With Connt
14-100783-000	Assy - 24VDC Solenoid Valve
14-100784-000	Assy - 24VDC Valve Cond. Tank Vent
14-100791-000	Assy - Conditioner Tank Complete
14-100810-000	Assy - Cable DC Contr To Speed Tank
14-100811-000	Assy - Cable, DC Contrlr, PCB Pres W
14-100812-000	Assy - Cable DC GUI Elect Cont Encls
14-100815-000	Assy - Cable, DC Charging Port
14-100838-000	Assy -Emergency Stop, DC Lane Machne
14-100893-000	Clamp - Battery - Lithium
14-100907-000	Receiver - 3 Function Remote Control
14-100907-001	Transmitter - Remote, One Button
14-100910-000	Assy - Cleaner Manifold
14-100914-000	Assy - 24VDC VAC Motor With Con Seal
14-100924-115	Battery Charger (115V)
14-100924-230	Battery Charger (230V)
14-100931-000	Assy In-Line Fuse, AGM Battery
14-100932-000	Assy -Cable, DC Contrlr PCB Rmt Rcvr
14-100942-000	Assy - Liquid Level Sensor Switch
14-100945-000	Assy - Indicator Audio Beep
14-100956-001	Assy - Jumper, AC/DC Power Supply
14-100956-002	Assy - Jumper Lithium Battery
14-100956-003	Assy - Jumper, AGM Battery
14-100957-001	Assy - AC/DC Power Supp Cable w/ Jump
14-100957-002	Assy - Lithium Battery w/ Jumper
14-860208-024	Pkg - Power Cord, Lane Machine
14-860245-000	Pkg - Power Supply For GUI
14-860246-000	Pkg - Emergency Run Display
R8-040000-000	Mnc- Pkg Battery - 12 VDC AGM (Pair)

AUTHORITY22®

PART NUMBER	DESCRIPTION
R8-020009-000	A22 1st Yr Tune-up Kit (1.6-115V)
R8-020009-200	A22 2nd Yr Tune-up Kit (2.0-115V)
R8-020009-400	A22 1st Yr Tune-up Kit (2.0-115V)
R8-020009-600	A22 2nd Yr Tune-up Kit (1.6-115V)
11-616030-115	Circuit Breaker (16 AMP) - Thermal 115V
14-100275-120	Vacuum Motor W/Connectors 120V
11-655013-010	Tubing Clear - 1/4 OD x .170 ID x 20' lg
11-655039-007	Tubing Green - 1/4 OD x .125 ID x 20' lg
11-655043-006	Tubing Clear- 3/8 OD x .295 ID 20' lg
14-100556-091	Absorbent Wiper-V Squeegee #8 HP (V2.0)
11-005308-000	Screw- 5/16-24x 1-3/4" lg Buffer Brush
11-106649-000	Screw- 3/8-16x1/20DX2-1/2"Lg 8" Wheel
11-537051-000	Grip-E Ring .250 Dia - Buffer/Idler
11-600001-000	Connecting Link #40- Traction Drive Chain
11-600010-000	Connecting Link #25- Dispersion Roller Chain
11-603135-000	Split Ring - 1.150 Id
11-616025-000	Switch-Duster Cloth Up/Dn Lever Type
11-616026-000	Switch- .1A@125VAC, Buffer/Sq Up/Dwn
11-616031-000	Switch- Spdt Pin Plunger- Cord Kill
11-651034-000	Grommet - Pump Mount Plate
11-655002-000	Check Valve/Strainer-200 Mesh Clean
11-655003-000	Nozzle- 110" Cleaner
11-655004-000	Retainer- Tip, Cleaner Spray
11-655022-000	Gearbelt- Synchronous,1/2 W x 3/8 P
11-655024-004	Prefilter- Oil,Screen Only,Cyl 40x30
11-655029-001	Filter- Spin-On Oil, 10 Micron
11-655044-004	Filter- Screen Only, Cyl.50 x 250M
11-655052-000	Fitting-Tube 1/4 Od x 3/8 Stem Od
11-655053-000	Fitting-90 Degree Fixed Elbow
11-695010-000	Caster- 2" Dual Wheel
11-696946-000	Wheel- 8" Authority22
11-696956-000	Sensor Horizontal Level Gentech
14-100030-000	Mid Guide Wheel (Conical)
14-100043-000	Buffer Brush
R8-020009-100	A22 1st Yr Tune-up Kit (1.6-230V)

TOP MOVING LANE MACHINE PARTS

AUTHORITY22

PART NUMBER	DESCRIPTION
R8-020009-300	A22 2nd Yr Tune-up Kit (2.0-230V)
R8-020009-500	A22 1st Yr Tune-up Kit (2.0-230V)
R8-020009-700	A22 2nd Yr Tune-up Kit (1.6-230V)
11-616030-230	Circuit Breaker (10 AMP) - Thermal 230V
14-100275-240	Vacuum Motor W/Connectors 240V
14-100074-003	Leather Pad - .08 x .62 x .75
14-100081-002	Foam Tube- Duster, 1.62ld x .75 x 43L
14-100086-001	Valve- Solenoid w/ Conn, Brass Oil
14-100126-000	Blade-Squeegee 60 Duro Flat Urethane (V1.6)
14-100138-000	Caster- 3" Swivel
14-100141-000	Block-Over Travel Upper A22 L/M
14-100235-091	Cable, End Lane Sensor
14-100254-000	Cable, Speed Sensor
14-100498-000	Emergency Stop Switch
14-100277-000	Duster Motor w/ Connector
14-100279-000	Front Wheel Guide (Conical)
14-100918-000	Cable, G.U.I. Power/Communication
14-100320-000	Wiper - Absorbent Squeegee (V1.6)
14-100323-000	Injector - Conditioner
14-100353-000	Line Strainer, Cleaning System
14-100363-000	Foam - Buffer Brush Shield
14-100374-000	Foam - Squeegee Clamp
14-100378-000	Foam - Vacuum Diffuser
14-100390-000	Foam - Middle Frame Section
14-100427-000	Foam - Buffer Shield Drip (V2.0)
14-100430-000	Grommet-Conditioner/Cleaner Tanks
14-100481-000	Assy Conditioner Filter
14-100487-000	Seal - Waste Tank, "D" Shape
14-100521-091	Absorbent Wiper-V Squeegee #6 (V2.0)
14-100523-091	Blade, V-Squeegee (V2.0)
14-100531-000	Assy Transition Wheel
14-100543-000	Assy Over Travel Block
14-100557-000	Foam Buffer Shield Drip, Wedge Shape HPV2.0)

OTHER PARTS

PART NUMBER	DESCRIPTION
1530001	Transport Caster 3-1/2" Bore
1530005B	45" x 5" Glueless Wick Material
1530005K	L/W Wick Replacement Kit
1530204H	Vacuum Motor Housing, 110V - ea
1530207	Spray Tip-Stainless Steel (8003)
1530207A	Lcm Spray Tip (TP11003-SS)
1530208S	Sprayhose 1/4" Od Per Inch
1530217	Connector-Male Body 1/4" Nylon
1530218	Tip Retainer Cap Connector
1530220	Screen Check Valve Polypropylene 10#
1530402	Double 2" Transport Caster
1530812	Transport Caster Heavy Duty 2"
1530815	Union Tee Quick Disconnect ea
1531012	Speed Control Board/DC Motor
1531016	Relay, LY-2 - 120 Volt
1531018	Relay, LY-3 - 120 Volt
1531027	Solenoid 110V
1531031A	Sensor, Pass Through (Omron)
1531202	Switch, Micro - No Roller
1531203	Squeegee Position Microswitch
1532006	Flat Washer - 3/88
1532401	Spring Guide, Roller
1532407	Shoulder Bolt, Guide Roller
1532540A	Wiping Pad Spring (1-3/4")
1536417	Mounting Bar, Guide Roller (Xl)
1537005R	Momentary Wheel Radius Edge
1538017	Buffer Brush Assy 4-1/2" Dia.
1538065	Drive Motor (Maxi-Torq 110V)
1538103A	Assy 3" Wick Plate W/Pads Models A&B
1538105A	Assy 5" Wick Plate W/Pads Models A&B
1538107A	Assy 7" Wick Plate W/Pads Models A&B
1538110A	Assy 10" Wick Plate W/Pads Model A&B
1538204	Squeegee Blade Rplmnt-Pr Blue
1538205	Vacuum Motor Assy 110 Volt
1538207	Squeegee Brake Motor Assy

OTHER PARTS

PART NUMBER	DESCRIPTION
1538403	Motor, Duster Cone Brak-7/110V
1538407	Buffer Brush Assy (3-3/4" Dia)
1538410	Assy, Lane Edge Gd Rol w/Bshng
1538410K	Guide Roller Assy
1538805	Qx Vacuum Motor 220V/96 CFM
1538824	Pvc Take-Up Reel Assy 44-3/4"
1538834	Px Squeegee Kit, Brown (2/Pkg)
1538838	Cushion Rllr Assy w/Stems-Px Pxs Xl
1539015	Buffer Timing Pulley Belt
1540007	Spray Tip - Stainless Steel
1540202	Pump Tubing Stock 3/8" Od x 1/4" Id
1540202A	Pencil Tubing Stock 1/4" Od x 1/8" Id
1540202B	Pencil Tubing Stock 3/16" Od x 1/16" Id
1540212	Tank Filter (5" SS)
1540212B	Filter For Supply Tank (5" SS) PVC
1540248	Reducing Union Connector
1540255	In-Line Filter
1540260	Flexible Hose Stock/Vacuum By Inch
1541209	Valve For Oil Control 24V DC
1541220	Sensor - Inductive Prox.
1541262	Fuse-Time Delay (.75A MDL) UI
1541268C	Fuse-Time Delay (4A ABC) UI-Ceramic
1548210	Circuit Board Assm/ Speed Cont
1548229A	Cord Asm 125' 110V 3800S 20 AMP Plug
1548267	Filter Assy (In-Line) For Oil Supply
1548617	Pattern Smoothing Pad Assy-Standard
1548617V	Velcro Stock-Pat Smoothing Pad 1x3
1548641	Buffer Brush Assembly - Standard
1548684	Recvry Tank Repl. Filter For 1548683
1548805	Vacuum Motor Assy 115/120V Kustodian
1548805E	Vacuum Motor Assy 230V Kustodian
1548817	Check Valve Assembly For Tank Vent
1548867	In-Line Cleaner Filter

LANE FINISH



Cosmic Astrolane® LF Lane Finish

62-860020-000 (Case of 8 kits)

Low-friction top coat that GLOWS! Squeegee over traditional top coat to keep balls going longer in the heads while reducing overreaction on the back ends.

- A two-component, 100% solids type finish
- Apply with Astrolane 100% Solids applicator assembly (14-860111-000) and 100% Solids applicator refills (14-860108-000)
- Counteracts conditioner depletion
- One kit covers 3 heads, 1-1/2 lanes when applied to the lane conditioner pattern distance or 1 lane when applied from foul line to pin deck



Astrolane® 100 Topcoat

62-860005-000 (Non-glow)

62-860124-000 (Glow-in-the-Dark)

Choose the finish that others strive to match.

- Astrolane 100 Topcoat is the industry standard for durability and appearance
- It's so durable that it often lasts a whole season under normal conditions, virtually eliminating the need for midseason recoating
- Nonflammable with low odor
- Sold in cases of eight kits. One kit per lane
- Apply using 100% Solids Applicator (14-860111-000) and 100% Solids Applicator Refills (14-860108-000)
- VOC compliant in all VOC restricted areas



Astrolane® 100 Basecoat

62-860018-000

Team up this premium basecoat with Astrolane 100 Topcoat for the best system in the industry.

- Offers a solid foundation for Astrolane or other finish systems
- May be used with a variety of lane finish topcoats
- Excellent adhesion characteristics provide superior durability and long life
- Features a special lightening agent to enhance the natural beauty of pine and maple
- Gives old lanes the lighter, cleaner look of new wood
- Nonflammable with low odor
- Sold in cases of eight units. One kit per lane
- Apply using 100% Solids Applicator (14-860111-000) and 100% Solids Applicator Refills (14-860108-000)
- VOC compliant in all VOC restricted areas



Cosmic Astrolane® E-Z Topcoat

62-860119-000 (One 1.7 Gallon kit)

All the same durable characteristics as Astrolane E-Z Topcoat, plus UV additive to make lanes glow under ultraviolet lighting.

- Lanes appear normal under white lights
- Applied with the Astrolane E-Z Plus Applicator (61-860241-000) and Long Nap Applicator Refill (61-860242-000)
- Can be used to recoat a variety of compatible topcoats
- VOC compliant in all VOC-restricted areas
- Each kit coats five lanes



Astrolane® E-Z Topcoat

62-860088-001 (One 1.7 Gallon kit)

Easy-to-use topcoat combines the strength and durability of 100% solids technology with the ease of conventional lane finish application.

- Extremely durable urethane finish with the same beautiful appearance as Astrolane 100 Topcoat
- A favorite of top-notch resurfacers
- Apply with Astrolane E-Z Plus Applicator (61-860241-000) and Long Nap Applicator Refill (61-860242-000) or with Slide-In Applicator (61-860183-000) and Mohair Applicator Refill (61-860185-000)
- Can be used to recoat a variety of compatible lane finish topcoats
- VOC compliant in all VOC-restricted areas
- Each kit coats five lanes



Astrolane® E-Z Basecoat

62-860100-000 (One 1.7 Gallon kit)

Outstanding adhesion and a durable basecoat with conventional application.

- Two-component urethane system
- Applied with Astrolane 100 E-Z Plus Applicator (61-860241-000) and Foamback Applicator Refill (61-860243-000)
- Works well with any water-based moisture-cure, urethane, or E-Z Topcoat
- VOC compliant in all VOC-restricted areas
- Each kit coats five lanes



Brunswick Uni-Flex Basecoat

62-860153-005 (5 Gallons)

Produces unmatched adhesion with the safety and convenience of a water-based finish.

- This durable water-based basecoat is easy to apply with the Slide-In Applicator (61-860183-000) and Water-Based Finish Slide-In Applicator Refills (61-860184-000) or with the Astro E-Z Plus Applicator (61-860241-000) and Foamback Applicator Refill (61-860243-000)
- Dries quickly. Often in less than an hour
- Offers a high degree of flexibility to expand and contract with the lane, greatly reducing cracking, chipping, bruising, and feathering
- Recommended for new or uninjected lanes
- Nonflammable and virtually odorless
- Use in a three-coat system with two coats of Brunswick Hydrolane Topcoat
- VOC compliant in all restricted areas
- Includes additive and whitener
- Each container coats up to seven lanes

Uni-Flex White Additive

62-860301-000 (3 oz. bottle)

Included with Uni-Flex Basecoat.

Uni-Flex Catalyst

62-860201-000 (12 x 13 oz.)

Included with Uni-Flex Basecoat.



Astrolane® WB Approach Finish

62-860019-000 (Four 1-Gallon containers)

62-860019-001 (1-Gallon)

This great looking approach finish is a favorite of industry professionals.

- Highly durable approach finish rarely needs midseason recoating
- One-coat application dries in one to three hours



Brunswick Hydrolane™ Topcoat

62-860200-005 (5 Gallons)

Get an unbeatable combination of exceptional durability and consistently high-scoring characteristics.

- Textured surface holds conditioner in place to help minimize changing lane conditions as bowling progresses
- Extremely durable water-based finish provides a full season of service in most lane situations, virtually eliminating the need for midseason recoating
- Low odor and nonflammable to help minimize shut-down time
- Easy to apply. Dries completely in four to six hours
- Use over Astrolane 100 Basecoat, E-Z Basecoat or Brunswick Uni-Flex Basecoat
- Apply using Slide-In Applicator (61-860183-000) and Water-Based Finish Slide-In Applicator Refills (61-860184-000) or with the Astro E-Z Plus Applicator (61-860241-000) and Foamback Applicator Refills (61-860243-000)
- VOC compliant in all restricted areas
- Includes additive
- Each container coats up to seven lanes

Hydrolane Catalyst

62-860202-000 (12 x 13 oz.)

Included with Hydrolane Topcoat.

Hydroglow Additive

62-860500-000 (1 x 14 oz.)

The perfect glow-in-the-dark additive for water-based topcoat finishes.

- One 14-ounce additive per five gallons of Hydrolane water-based topcoat provides excellent glowing lanes when exposed to UV lighting
- Not for use with water-based approach finish

- Clean up with soap and water
- Provides uniform slide characteristics
- Resistant to toe and ball marking
- Apply using Approach Applicator (61-860110-000) and Approach Applicator Refill (61-860110-005)
- VOC compliant in all restricted areas
- Each gallon coats up to six approaches



U-300 Single Package Ultraviolet Finish

62-860172-005 (5 Gallons)

This moisture-cure urethane topcoat looks completely clear under standard lighting, and emits a blue-white aura under ultraviolet conditions.

- Hard, durable finish that requiring no additional clear topcoat
- Each container coats up to seven lanes
- May not be permitted in your area due to local VOC restrictions; check your local VOC regulations or contact your Brunswick distributor for details



U-300 Ultra High Solids UV Topcoat

62-860195-005 (5 Gallons)

Same great benefits as U-300 Ultra High Solids Topcoat with the addition of an ultraviolet pigment for superior glow under black lights.

- Each container coats up to eight lanes

FINISH APPLICATORS

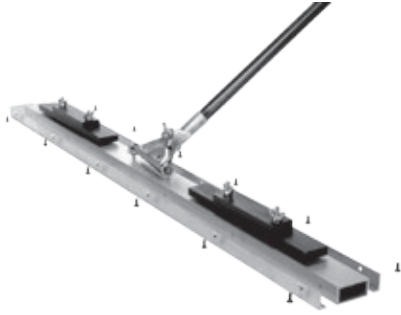

Universal Lane Finish Applicator

61-860188-000

This economical applicator is designed for conventional application of water-based, moisture-cured urethane and Astrolane E-Z lane finishes.

- Designed to give the user the best view of the finish “puddle” to eliminate mistakes
- Slide-in applicator is easy to assemble
- Includes three sizes of adjustable weights to control film thickness
- Designed for use with Slide-In Applicator Refills
- Not designed for use with 100% Solids coatings



Astro E-Z Plus Applicator

61-860241-000

Designed for conventional application of most bowling lane finishes and a must for application of E-Z Basecoat and Topcoat.

- Ideal for application of water-based urethane and moisture-cure urethane, Astrolane E-Z Basecoat and Astrolane E-Z Topcoat
- Application is simplified. No need to carry a heavily weighted applicator from lane to lane
- Not designed for use with 100% solids coatings
- Use with specially designed adhesive-backed Astro E-Z Plus Applicator Refills



100% Solids Applicator

14-860111-000

This unique applicator is specially designed for applying 100% solids lane finishes and Astrolane Lane Sealer.

- Unique design ensures smooth, good looking finish application
- Includes 100% Solids Applicator Refills (14-860108-000)
- Non-marking wheels make it easy to push down lane
- Quick-release handle for easy coating of pin decks
- Adjustable ears prevent finish from spilling into the gutters
- Comes complete with weights so film thickness can be controlled

Water Base Approach Finish Applicator

62-862120-000

- For use with WB approach finish
- Use with refill 61-860110-005

APPLICATOR REFILL AND APPLICATOR CHART

Part Number	Description	Applicator
61-860242-000	Long Nap, Adhesive Refill (box of 5)	61-860188-000 and 61-860241-000
61-860243-000	Wide, Foam backed, Adhesive Refill (box of 6)	61-860188-000 and 61-860241-000
61-860244-000	Terry Cloth, Adhesive Refill (box of 6)	61-860188-000 and 61-860241-000
14-860108-000	100% Solids Applicator Refills (box of 2)	14-860111-000
61-860184-000	WB Finish Slide-In Refills (box of 6)	61-860188-000
61-860185-000	Mohair Slide-In Refills (box of 5)	61-860188-000
61-860110-005	WB Approach Applicator Refill (box of 6)	62-862120-000

FINISH APPLICATORS



100% Solids Applicator Refills

14-860108-000

For a perfect finish application, start by replacing worn or damaged applicator refills.

- Cushioned refill ensures that a smooth contour is applied to all lane surfaces and lane imperfections
- Durable urethane material cannot be damaged by lane finish, so long life is assured
- Refill conforms to exact Brunswick tolerances to assure a consistent and even finish film thickness
- Refill includes ears and foam cushions
- Keep a few in stock to always be prepared
- Two refills per package

Misc. Lane Applicator Part Refills

180301PAW Water based refill pads for Perry-Austen applicator (5 per box)

- Screw-on

Foamback Applicator Refills

61-860243-000

- For use with all water-based lane finishes
- Package of six



Mohair Slide-In Applicator Refills

61-860185-000

This applicator board makes Astrolane E-Z Topcoat and moisture-cure urethane topcoat finish jobs look fantastic.

- Assures a proper amount of finish is applied while eliminating waste & saving money
- Finish flow is consistent, from edge board to edge board
- For use with Astrolane E-Z Topcoat and moisture-cure urethane topcoats
- Installs easily in Slide-In Applicator
- Use with Slide-In Applicator (61-860183-000)
- Package of five

Long Nap Applicator Refills

61-860242-000

- For use with moisture-cure urethane topcoats and Astrolane E-Z Topcoat and E-Z Basecoat
- These adhesive-backed refills ensure quick fastening and removal from the E-Z Plus Applicator Long Nap Applicator Refill
- Package of five



Water-Based Finish Slide-In Applicator Refills

61-860184-000

Perfect for applying water-based finishes.

- Synthetic foam-flocked material ensures that the proper amount of finish is applied every time, eliminating waste and saving money
- Finish flow is consistent across the lane, assuring complete coverage of edge boards
- Use with Slide-In Applicator (61-860183-000)
- Package of six



Approach Applicator Refill

61-860110-005

This 18" foam-flocked applicator refill is ideal for applying Astrolane WB Approach Finish (62-860019-000).

- Cleans easily with water

WB Lane	WB Approach	100% Solids	E-Z Base	E-Z Top	Moisture Cure	HS Moisture Cure	Grain Stain	Lane Sealer
			X	X	X	X		
X							X	
		X						X
X				X	X	X		
	X							

BANKSHOT BUMPER BOWLING & FOUL LINE DECAL

Bankshot™ Bumper Bowling System (1 Lane Kits)

- 171801GK Medium Gray
- 171801K Charcoal
- 171801BK Black

The affordable bumper bowling system that will bring in the bucks, from bumper leagues to bumper birthday parties.

- Easy to install
- Pays for itself fast, turning revenues to pure profits
- Made with all-metal uprights for improved durability and performance
- Goes from up-and-ready to out-of-sight quickly and easily
- Can be automated or integrated with Vector® and Frameworx® scoring at any time
- Bankshot colors complement any décor

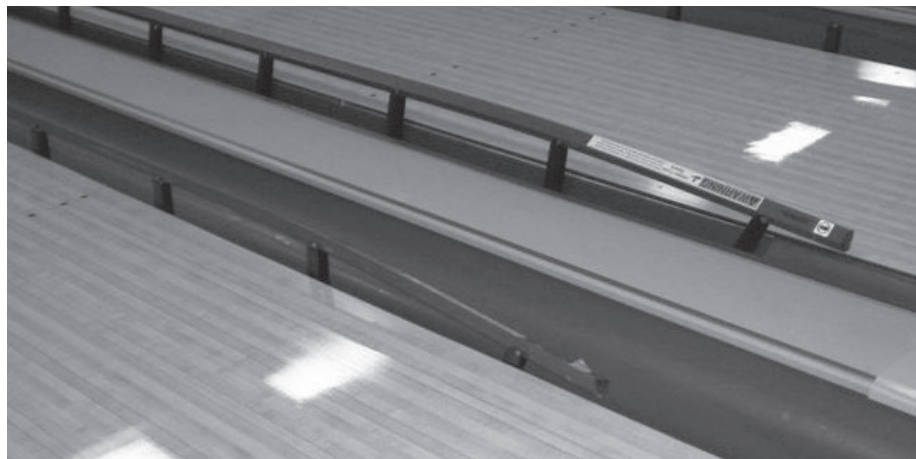

Bankshot Channel Only Kits

- 171805K Charcoal Channel Only Kit
- 171805GK Medium Gray Channel Only Kit
- 171805BK Black Channel Only Kit

Bankshot Rail Upgrade Kits

- 171806K Charcoal Rail Upgrade Kit
- 171807K Medium Gray Rail Upgrade Kit
- 171806BK Black Rail Upgrade Kit

Bankshot Upgrade Kits

- 84-860703-000 Gas Spring and Hardware – Single Lane Kit
- 84-860715-000 Gas Spring and Hardware – Two Lane Kit
- 11-210005-000 Gas Spring only
- 84-860716-000 Drill Package for Gas Spring Upgrade
- 84-860100-000 Tool Package Improved deployment tool for raising Bankshot
- 84-860719-000 Vertical Supports (28 Pk) Includes Washers and Rubber Bushings
- 84-860720-000 Vertical Supports (60 Pk) Does NOT include hardware
- L2-600074-000 Short Vertical Upgrade

This new half size support reduces possible damage to the head rail from ball impact. Upgrade package includes 4 short vertical supports with connecting pins.

- 84-200472-000 Tool E-Clip Specialty tool for E-clip installation

Part Number	Replacement Rail Sections
84-200478-XXX	LH Pinsetter End Rail
84-200479-XXX	RH Pinsetter End Rail
84-200451-XXX	Common Rail
84-200452-XXX	LH Foul Rail
84-200453-XXX	RH Foul Rail

Part Number	Replacement Rail & Gutter sections
84-860160-XXX	Pkg-Rail/Gutter Sect LH Foul
84-860161-XXX	Pkg-Rail/Gutter Sect RH Foul
84-860162-XXX	Pkg-Rail/Gutr Sect LH Common
84-860163-XXX	Pkg-Rail/Gutr Sect RH Common
84-860164-XXX	Pkg-Rail/Gutr LH Pinset End
84-860165-XXX	Pkg-Rail/Gutr RH Pinset End

Part Number	Replacement Gutter Covers
84-860622-XXX	Gutter Cover Pkg 118"
84-200465-XXX	Gutter Cover 31.125"

REPLACEMENT RAIL & GUTTER COLOR CHART

COLOR	SUFFIX*
BLACK	000
DARK GREY	100
MEDIUM GREY	142

Part Number	Replacement Miscellaneous
84-200457-000	Coupler - Rail
84-200463-002	LH Rail Plug Pkg
84-200463-001	RH Rail Plug Pkg
84-200458-001	Pin - Connecting, Upper Arm
84-200458-003	Pin - Connecting, Rail Joint
84-200487-000	Rubber Bushing - Vertical Support
11-537050-000	Retaining Ring
84-200458-004	Pin - Connecting
84-200462-000	Gutter Coupler
84-200459-000	Pin-Connecting, 1.940" Lg
11-537050-000	Retaining Ring
84-200488-000	Decal - Hand Warning
11-682561-000	Label - Warning For Bankshot



Foul Line Decal (Pkg of 6)



- 84-860266-000 - ENGLISH
- 84-860269-000 - SPANISH

Help keep your bowlers behind the foul line with this new Foul Line Decal. This USBC approved decal is easy and quick to install using the step by step instructions that are included in the package. Made with Guardian, the decal provides great glow under black lights.

GUARDIAN & RESURFACING SUPPLIES

Guardian®

84-860517-000 (124' Glow-in-the-Dark)

Extend the life of wood lanes and gain control of the entire lane maintenance program.

- Add years to the life of lanes
- Covers from edge to edge
- Minimizes ball damage to lanes
- Reduces need to recoat or resurface



Powdered Oil Vac™ Lane Oil Remover

62-860074-000

Do the job right. Properly treat the bare wood before applying the basecoat finish.

Contains a powerful absorbent material for drawing conditioner out of wood.

- Improves adhesion of basecoat finish to wood surface while returning wood to original, natural color
- Specially formulated powder is fast-acting and odorless
- Easy to apply and clean up
- Multiple applications may be required for heavily oil soaked lanes
- One 50 lb. bag covers six to eight heads



Shield Urethane Coating

62-860063-001 (Gallon)

A routine coat of Shield urethane decreases wood damage and increases pin deck life.

- Use on wood pin decks, flat gutters and kickbacks
- Easy-to-apply clear urethane coating dries to a smooth, durable finish
- One gallon covers approximately 300 to 500 square feet
- Note: Brunswick Shield contains volatile organic compounds (VOCs). Before using, check local regulations for VOC restrictions



Astrolane® Sealer

62-860130-000 (1 Gallon kit)

This fast-drying, pre-base coat stain and sealer coat gives older, oil-soaked wood lanes a lighter appearance and allows the base coat to protect the lane.

- Two component, 100% Solids type formulation
- VOC Compliant
- Prevents base coat from soaking into wood
- Results in a smoother, higher-gloss lane finish system
- Apply with Astrolane 100% Solids applicator assembly (14-860111-000) and 100% Solids applicator refills (14-860108-000)
- One gallon kit covers 8 lanes



Injection Epoxy

61-860712-005

(White Compound A—5 Gallon Container)

61-860713-005

(Brown Hardener B—5 Gallon Container)

More lanes have been injected with this injection compound than all other epoxies combined. With an original process, epoxy is injected into the tongue and groove of lanes, completely filling the areas between the boards, bonding the boards together.

- Eliminates feathering; greatly reduces wood damage due to board movement
- Lanes will last longer. Resurfacing won't require sanding off as much wood
- Use two parts Compound A with one part Hardener B
- (Was Perry Austen 2D30030599 - A and 2D30040599 - B)



Brunswick Injecta-Patch Lane Epoxy

61-860256-000 (3 oz cartridge*)

61-860257-000

(static mix tube for 3 oz cartridge*)

61-860258-000

(3 oz cartridge trigger dispenser)

61-860259-000 (14 oz cartridge*)

61-860260-000

(static mix tube for 14 oz cartridge*)

61-860261-000

(14 oz cartridge Heavy Duty trigger dispenser)

61-860262-000

(3 oz plunger for older trigger dispensers)

This epoxy formulation is designed to look more like wood and to sand like wood. The heavy duty, 14-oz cartridge trigger dispenser has the power to inject epoxy into lanes; more convenient than injection machines for injection repair or lane injection of a few lanes.

- Fast curing
- Sands like wood

* Sold individually

RESURFACING SUPPLIES



Perma Grip Pad Holder

61-860097-000

Ensure that the synthetic pads stay firmly in place when cleaning, polishing, or conditioning lanes and floors.

- Features 1/2"-long tufts of untrimmed polypropylene widely spaced on the face of the disc
- The individual filament brushes penetrate the synthetic pad and hold it in place
- Allows operator to heel lane machine without recentering the pad
- This holder is designed so that larger polishing pads can also be used
- **WARNING:** Do not use brush or pad with flammable materials (fuels, solvents, thinners, etc.). Serious injury could result from fire or explosion



Cleaning Dura Pads (Black)

61-860023-000 (Package of 10 - Black)

These pads are designed to handle the toughest floor cleaning jobs.

- Excellent for heavy-duty cleaning
- Thin, black pads are constructed from durable, nylon web
- 19" pads fit most floor buffing machines

CAUTION: Test before using. May abrade some surfaces.



Scrubbing Dura Pads

61-860027-000 (Pkg of 10 - Thin, Green) - 20"

61-860117-000 (Pkg of 5 - Thick, Tan) - 19"

Keep pads in stock to ensure a well maintained center.

- Pads are made from durable, woven nylon fibers
- Excellent for applying conditioner, polishing, and light cleaning duties
- Use with all rotary floor machines
- Wash and reuse
- Available in two thicknesses
- Pads fit most floor buffing machines



19" Cotton Buffing Bonnet Pad

62-860193-000

The 19" cotton buffing bonnet pad can be used with rotary floor machines to buff and polish approaches. For optimal absorption the buffing bonnet should be washed prior to use.



Treated Paper

61-860032-000 (Sheet)

Capture excess finish while protecting covered surface from damage.

- Specially treated paper prevents finishes from soaking through to the area beneath it
- Reduces cleanup time by collecting excess finish
- Not just for resurfacing work
- Sheet dimensions are 45" x 48"

Rotary Buffer Screens

61-860034-002 - 80 Grit, 18" Square, Each

61-860034-003 - 180 Grit, 18" Square, Each

61-860034-006 - 240 Grit, Silicon Carbide, 5pk

61-860034-007 - 320 Grit, Silicon Carbide, 5pk

Tack Cloth

61-860026-250 (250 yard roll)

Eliminate all dust and grit that can interfere with the perfect coating job.

- This sticky cloth attracts and holds particles to produce an extremely clean surface
- Leaves lanes perfectly clean
- Use after screening to pick up dust and particles
- A "must-use" for a professional-looking finish

REPLACEMENT LANE PANELS

7/16" Anvilane Lane Panels (special order only)

84-200261-000 - 7/16" Maple Laminate Plate Finish
84-200262-000 - 7/16" Foul Line Laminate Plate Finish
84-200263-000 - 7/16" Pine Plate Finish Panel
84-200265-000 - 7/16" Approach Plate Finish Panel
84-200266-000 - 7/16" Division Plate Finish Panel
84-200267-000 - 7/16" Return Plate Finish Panel
84-200272-000 - 7/16" Head Plate Finish Panel

GID 7/16" Anvilane Lane Panels (special order only)

84-200261-900 - GID 7/16" Maple Laminate Plate Finish
84-200262-900 - GID 7/16" Foul Line Laminate Plate Finish
84-200263-900 - GID 7/16" Pine Plate Finish Panel
84-200265-900 - GID 7/16" Approach Plate Finish Panel
84-200266-999 - GID 7/16" Division Plate Finish Panel
84-200267-999 - GID 7/16" Return Plate Finish Panel
84-200272-900 - GID 7/16" Head Plate Finish Panel

3/8" Anvilane Lane Only Lane Panels (special order only)

84-200718-000 - 3/8" Lane Only LH Foul Line Panel
84-200719-000 - 3/8" Lane Only RH Foul Line Panel
84-200720-000 - 3/8" Lane Only LH Arrow Panel
84-200721-000 - 3/8" Lane Only RH Arrow Panel

GID 3/8" Anvilane Lane Only Lane Panels (special order only)

84-200718-999 - GID 3/8" Lane Only LH Foul Line Panel
84-200719-999 - GID 3/8" Lane Only RH Foul Line Panel
84-200720-999 - GID 3/8" Lane Only LH Arrow Panel
84-200721-999 - GID 3/8" Lane Only RH Arrow Panel

3/8" Non Textured Anvilane Lane Panels (special order only - 89" t-panel)

84-200614-000 - 3/8" LH Approach Panel
84-200615-000 - 3/8" RH Approach Panel
84-200616-000 - 3/8" LH Foul Line Panel
84-200617-000 - 3/8" RH Foul Line Panel
84-200618-000 - 3/8" LH Arrow Lane Panel
84-200619-000 - 3/8" RH Arrow Lane Panel

GID 3/8" Non Textured Anvilane Lane Panels (special order only - 89" t-panel)

84-200614-999 - GID 3/8" LH Approach Panel
84-200615-999 - GID 3/8" RH Approach Panel
84-200616-999 - GID 3/8" LH Foul Line Panel
84-200617-999 - GID 3/8" RH Foul Line Panel
84-200618-999 - GID 3/8" LH Arrow Lane Panel
84-200619-999 - GID 3/8" RH Arrow Lane Panel

3/8" Non Textured Anvilane Lane Panels (special order only - 85.5" t-panel)

84-200663-000 - 3/8" LH Approach Panel
84-200664-000 - 3/8" RH Approach Panel
84-200666-000 - 3/8" RH Foul Line Panel
84-200665-000 - 3/8" LH Foul Line Panel

GID 3/8" Non Textured Anvilane Lane Panels (special order only - 85.5" t-panel)

84-200663-999 - GID 3/8" LH Approach Panel
84-200664-999 - GID 3/8" RH Approach Panel
84-200665-999 - GID 3/8" LH Foul Line Panel
84-200666-999 - GID 3/8" RH Foul Line Panel

Lane Panels Anvilane Non Text 3/8" (special order only)

84-200661-000 - 3/8" Narrow Ball Return Fill Panel
84-200722-000 - 3/8" Walkway Fill Panel

GID Lane Panels Anvilane Non Text GID 3/8" (special order only)

84-200661-999 - GID 3/8" Narrow Ball Return Fill Panel
84-200722-999 - GID 3/8" Walkway Fill

Lane Panels Anvilane Textured 3/8" (special order only)

84-200705-000 - 3/8" Textured LH Common Panel
84-200706-000 - 3/8" Textured RH Common Panel
84-200707-000 - 3/8" Textured LH Arrow Panel
84-200708-000 - 3/8" Textured RH Arrow Panel
84-200709-000 - 3/8" Textured LH Short Panel
84-200710-000 - 3/8" Textured RH Short Panel
84-200711-000 - 3/8" Textured LH Approach Panel
84-200712-000 - 3/8" Textured RH Approach Panel
84-200713-000 - 3/8" Textured LH Foul Line
84-200714-000 - 3/8" Textured RH Foul Line
84-200715-000 - 3/8" Textured Mo Ball Return
84-200716-000 - 3/8" Textured Narrow Ball Return Fill
84-200717-000 - 3/8" Textured Walkway Fill

GID Lane Panels Anvilane Textured 3/8" (special order only)

84-200705-999 - GID 3/8" Textured LH Common Panel
84-200706-999 - GID 3/8" Textured RH Common Panel
84-200707-999 - GID 3/8" Textured LH Arrow Panel
84-200708-999 - GID 3/8" Textured RH Arrow Panel
84-200709-999 - GID 3/8" Textured LH Short Panel
84-200710-999 - GID 3/8" Textured RH Short Panel
84-200711-999 - GID 3/8" Textured LH Approach Panel
84-200712-999 - GID 3/8" Textured RH Approach Panel
84-200713-999 - GID 3/8" Textured LH Foul Line
84-200714-999 - GID 3/8" Textured RH Foul Line
84-200715-999 - GID 3/8" Textured Mo Ball Return
84-200716-999 - GID 3/8" Textured Narrow Ball Return Fill
84-200717-999 - GID 3/8" Textured Walkway Fill

GID Lane Panels Prolane (special order only)

84-200436-999 - GID Prolane RH Approach Panel
84-200437-999 - GID Prolane LH Approach Panel
84-200438-999 - GID Prolane RH Foul Line Panel
84-200439-999 - GID Prolane LH Foul Line Panel
84-200440-999 - GID Prolane Ball Return Fill Panel
84-200445-999 - GID Prolane Wide Ball Return Fill Panel
84-200446-999 - GID Prolane Walkway Fill Panel

GID Lane Panels Prolane Textured (special order only)

84-200696-999 - GID Textured Prolane RH Approach Panel
84-200697-999 - GID Textured Prolane LH Approach Panel
84-200698-999 - GID Textured Prolane RH Foul Line Panel
84-200699-999 - GID Textured Prolane LH Foul Line Panel
84-200701-999 - GID Textured Prolane Ball Return Fill Panel
84-200702-999 - GID Textured Prolane Wide Ball Return Fill Panel
84-200704-999 - GID Textured Prolane Walkway Fill Panel
84-200692-999 - GID Prolane Head Lane Panel
84-200693-999 - GID Prolane Lane Panel
84-200694-999 - GID Prolane With Characters
84-200695-999 - GID Prolane Short Lane

GID Lane Panels Prolane Lane Only (special order only)

84-200700-999 - GID Prolane Lane Only Foul Line

LANE PARTS



Maple Patching Stock

21-042538-000 (1 3/32" x 3/4" X LF)

21-033042-000 (1 9/64" x 3/4" X LF)

Used for repairing unsightly or broken boards in the approach, head or pin deck area.

- Highest-grade clear, select hardrock maple for maximum durability
- Kiln dried for dimensional stability
- Precision-milled for uniformity



Pine Patching Stock

21-033043-000 (1 9/64" x 3/4" X LF)

Used to repair heavily dented or broken boards in the pine section of the lane.

- Highest-grade select southern yellow pine
- Kiln dried for dimensional stability
- Precision-milled for uniformity

Urethane Foul Line

84-200365-000

Maple Face Boards

52-100291-000 (5-1/2")

52-100473-000 (6-1/2")



Red Fiber Dowel

52-200059-000 (1/2" x 3/4")

52-200060-000 (11/16" x 3/4")

Used to replace thin or worn lane marking guides.



Pine Dowel

52-100211-000 (11/16" x 2")



Maple Dowel

52-100203-000 (1/2" x 2")

52-100204-000 (11/16" x 2")

Used to cover holes when face-screwing a wooden head approach or pin deck.



Fiber Bed Spot

21-016034-000 (1/2")

High-quality material used to replace thin or broken bed spots.

- Conforms to USBC®/WIBC specifications for bed spot diameter
- Tough, impact-resistant material for maximum durability

Plywood Spline One-Piece Tailplank

84-200046-000

- Replaces worn tailplank on pin deck with durable plywood version

Lane Plugs

84-860600-999 Nylon Lane Plug GID (500 Pk)

84-860601-999 Nylon Lane Plug GID (50 Pk)

84-860600-000 Nylon Lane Plug (500 Pk)

84-860601-000 Nylon Lane Plug (50 Pk)

- Replacement plugs for ProLane™ or 3/8" Anvilane phenolic lane panels

Maple Epoxy Kit

61-860073-999 (GID)

61-860073-000 (Non-Glow)

Dow Corning 795 Silicone

84-200430-000 - Sandstone

84-200172-000 - Clear

Prolane Panel Sealer

84-860565-000

Kickback Plate

52-200005-002 (R.H. 7-pin side 16" x 40" front plate for GS-Series or armor frame)

52-200005-004 (L.H. 10-pin side 16" x 40" front plate for GS-Series or armor frame)

52-200005-003 (29" x 22" rear plate for GS-Series)

21-088674-000 (21-3/4" x 19" rear plate)

21-088675-000 (33" x 15" front wood kickback plate)

This solid, active kickback plate will provide improved pin action and more consistent scoring than old, dead plates.

- When kickback plates become soft or loose, they absorb energy from pins, reducing pin action and affecting bowlers' scores
- Durable, impact-resistant plate is made from a solid piece of phenolic material protecting wood kickback from damage over time
- Flexible material won't delaminate or splinter
- All sharp edges are removed to prevent damage to ball and pins
- Surface is non-marking to pins
- Sanded back surface ensures secure mounting. For strongest bond, use Brunswick Adhesive (11-676047-000)
- Predrilled

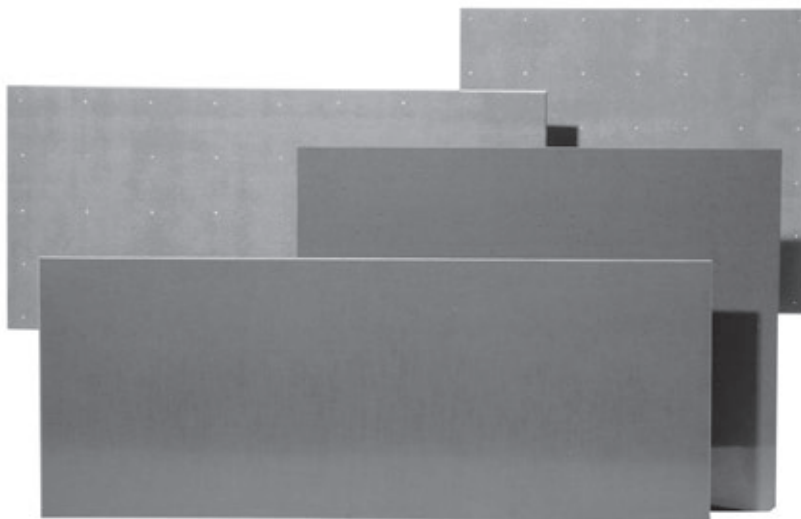

HDPE KickBack Plates

179855 HDPE Kickback Plate for AMF 15" x 33" (each)

179856 HDPE Kickback Plate for AMF 15" x 50" (each)

179857 HDPE Kickback Plate for Brunswick 16" x 40" (each)

179858 HDPE Kickback Plate for Brunswick 19" x 23-3/4" (each)

179855P HDPE Kickback Plate for AMF 15" x 33" (pre-drilled, each)

179856P HDPE Kickback Plate for AMF 15" x 50" (pre-drilled, each)

179857P HDPE Kickback Plate for Brunswick 16" x 40" (pre-drilled, each)

179858P HDPE Kickback Plate for Brunswick 19" x 23-3/4" (pre-drilled, each)

179859 Kickback Nails, 1", heat-treated twist nails (pound)

- Increases scoring
- Made of high-density polyethylene material. Never needs coating
- Single-piece construction prevents delamination
- Available pre-drilled

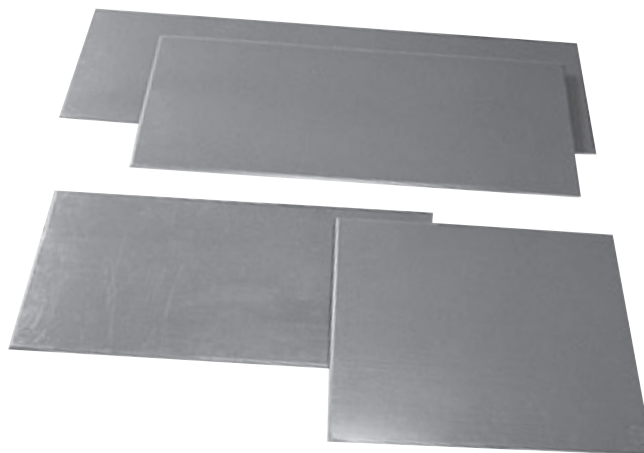

Brunswick HDPE Flat Gutter

84-860557-000

- Made from extremely durable high-density polyethylene material
- Quick and easy installation
- Lower maintenance costs. No coating is required
- 52" length can be cut to fit all lane configurations

80107B Flat Gutter (bottom only)

80108L Flat Gutter (left-hand side)

80108R Flat Gutter (right-hand side)



Brunswick Heavy Duty Flat Gutters

84-860504-000 (2 flat gutters per package)

Brunswick's best flat gutter. Virtually indestructible, made of Ultra High Molecular Weight polypropylene.

- Bottom of gutter is 1" thick with 3/4" sides
- Dark brown material won't mar pins or balls
- Easy to clean and maintain
- Sold as two flat gutters for one lane
- USBC/WIBC Approved

52-100472-001 - HD Gutter (bottom)

52-100472-002 - HD Gutter (RH side)

52-100472-003 - HD Gutter (LH side)



LANE PARTS

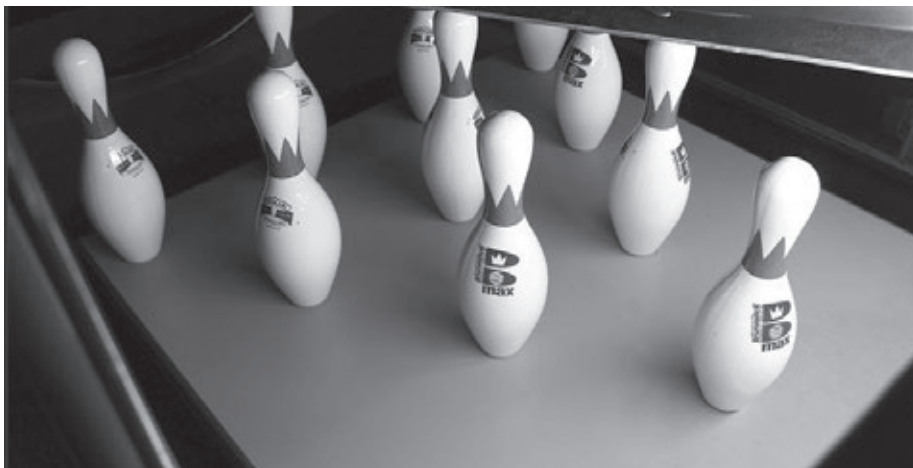

Brunswick Anti-Skid Pin Deck

418001K Anti-Skid Synthetic Pin Deck (each/ includes adjustable hardware)

418002K Anti-Skid Pin Deck (top screwed)

418526L Phenolic Edgeboard (7 Pin Side)

418526R Phenolic Edgeboard (10 Pin Side)

- Reduces sliding pins
- High-impact surface
- High-density core construction
- Adjustable hardware for replacement installations

Side Pin Deck Edge Molding

52-100243-001 (48" x 2-1/16" for old-style phenolic pin decks/synthetic lanes)

52-100078-000 (48" x 2-3/4" for old-style phenolic pin decks/wood lanes)

84-200084-010 (48" x 1-3/8" for integral pin deck/synthetic lanes)

Part numbers are listed in order from left to right on picture.

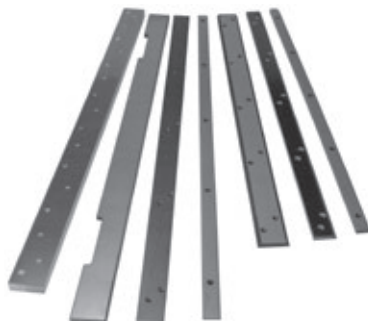

HDPE Pin Deck Edge Boards

179860 Pin Deck Edge Boards (each)

- Replacement edge boards for wood decks
- Made from extremely durable high-density polyethylene material
- Stronger than wood
- 1" x 2-1/2" x 46"

HDPE Tail Plank Cover Strips

179861 Tail Plank Cover Strip (each)

- Replaces entire worn upper sections on tail planks of wood pin decks
- Made from extremely durable high-density polyethylene material
- 1" x 1-3/4" x 43"

HDPE Tail Plank End Strips

179862 Tail Plank End Strips (each)

- Replaces worn phenolic or fiber end strips on tail planks of wood pin decks
- Made from extremely durable high-density polyethylene material
- 1-5/8" x 1/2" x 43"

Rear Pin Deck Edge Molding

52-100079-000 (40-3/4" x 2-3/4" for old-style phenolic pin decks/wood lanes)

52-100244-000 (40-3/4" x 2-1/16" for old-style phenolic pin decks/synthetic lanes)

84-200083-010 (40-3/4" x 1-3/8" for integral pin decks/synthetic lanes)

Extend the life of the pin deck by protecting its edges properly.

- Tough edge boards made from X-grade phenolic material can withstand the abuse of flying pins
- Rounded edges protect pins and balls from damage
- 1/2" thick for durability
- The 52-100078-000 edge boards have cut-outs to ensure proper fit. Install these edge boards with glue only (no screws necessary)
- When installing edge boards with glue, use Brunswick Adhesive (11-676047-000)



Gutter Header Block

84-200644-000

Provides an improved lane to gutter installation, eliminating custom fitting and preventing dirt from getting trapped underneath the block. An added back stiffener keeps the block from buckling and improves the movement of lane machine wheels into and out of the gutter. It can be used with all Brunswick round gutters and other round gutters.



Adapter Gutter Blocks (Bankshot/PBW)

84-200456-001 (R.H.)

84-200456-002 (L.H.)

Replace worn adapter blocks to ensure proper ball transition from Bankshot or PBW gutters to the flat gutter. Made from polypropylene material for great strength and durability.

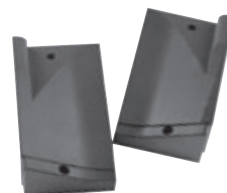

Adapter Blocks for UOS or VOS V Gutters

84-200117-002 (L.H.)

84-200117-003 (R.H.)

Precisely contoured to provide a smooth transition from a V gutter to a flat gutter.

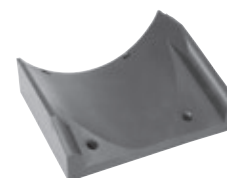

Adapter Block for Plywood or VOS Round Gutters

52-100020-600 (Gray, R.H. one piece)

52-100021-600 (Gray, L.H. one piece)

Replace worn adapter blocks so gutter balls won't bounce or be damaged when going from the round gutter to the flat gutter.



Brunswick[®]

Experience is Everything.

525 West Laketon Avenue
Muskegon, MI 49441-2601 USA
1-800-Yes-Bowl (Options 2,2,*)
1-231-725-4966 (Options 2,2,*)
inquiries@brunbowl.com
www.brunswickbowling.com

Go to www.brunswickbowling.com/contact/sale-rep/ to find a local Brunswick Sales Representative

Kegel is a registered trademark of KEGEL, LLC. Surlyn is a registered trademark of E.I. du Pont de Nemours and Company. USBC is a registered trademark of United States Bowling Congress, Inc. Windows is a registered trademark of Microsoft Corporation in the United States and/or other countries. IBM is a registered trademark of International Business Machines Corporation. All other trademarks belong to Brunswick Bowling Products, LLC.

Brunswick is committed to continuous improvement. As a result, all specifications and options are subject to change without notice. Not for reproduction without the express written consent of Brunswick Bowling Products, LLC.

©2016 Brunswick Bowling Products, LLC. Printed in the USA. • Item #10095400002 • Form #0616-01.

2016-2017 CATALOG