



AFTERMARKET PRODUCTS

Brunswick 



ENVOY® LANE MACHINE
See page 2

MYBALL™ SYSTEM
See page 21

PREMIUM RENTAL SHOES
See page 19

MAX10 LANE CLEANER
See page 13

DEFYv30™ LANE CONDITIONER
See page 10

HYBRID RENTAL SHOES
See page 19

ENVOY® LANE MACHINE	2-5	THROBOT™ INFORMATION & CHARTS	12	PINS	18
AUTHORITY22® LANE MACHINE	6-7	LANE CLEANERS & CLOTH	13	RENTAL SHOES	19
PHOENIX® LT4 LANE MACHINE	8-9	APPROACH SUPPLIES	14	MYBALL™ HOUSE BALLS	20
LANE MACHINE COMPARISON	9	MAINTENANCE SUPPLIES	15	MYBALL™ SYSTEM	21
LANE CONDITIONERS	10	BALLWORX® BALL POLISHER	15	BALL CARTS & BALL RAMP	21
LANE CONDITIONER COMPARISON	11	PINSETTER PARTS	16-17		



CUTTING-EDGE TECHNOLOGY MEETS REAL-WORLD EXPECTATIONS



Brunswick's dedication to advancing the experience of bowling is as evident today as it was 125 years ago. Brunswick continues that tradition with a strong commitment to research and development, technical engineering, and on-site training for proprietors and mechanics. From Throbot™ – our state-of-the-art ball-throwing robot – to our dedicated supplies development team, Brunswick continually invests in advanced scientific research to measure and enhance performance bowling products.

As the leading manufacturer of everything bowling – including a full line of lane maintenance products, pinsetter parts, and center operation supplies – Brunswick is in a unique position to assure each component works in harmony with all the others for the maximum good of the sport and your business.

Whether you are league-based or focused on open play, Brunswick values your business. That's why we have our engineers ensure Brunswick products represent the leading edge in quality, technology, and performance. Backed by the 24/7/365 support of Brunswick's Technical Services team, Aftermarket Product Specialists in North America, and dedicated distributors servicing centers in over 60 countries across the world, you will always get the very best performance and the very best value when you choose Brunswick products.

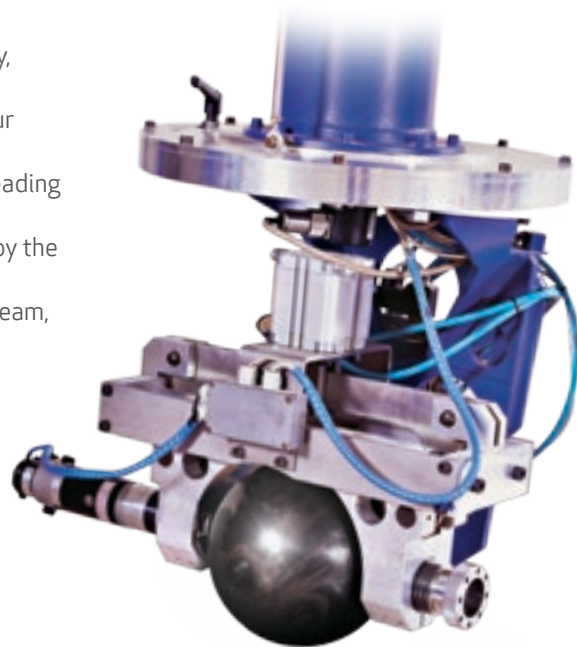

LANE MACHINES



Envoy®

**"MY SHOT HAS NEVER BEEN MORE CONSISTENT LANE TO LANE.
SCORES ARE UP. BOWLERS ARE HAPPY. BUSINESS IS GOOD."**

—BILL WAMMES, ALMAR LANES, BOWLING GREEN, OHIO—





KEEP YOUR LANE CONDITIONS CONSISTENT AND YOUR BOWLERS HAPPY WITH DIRECT+ CONDITIONING — THE NEW STANDARD IN LANE MAINTENANCE.

ENVOY® LANE MACHINE

For over 50 years, since the introduction of the B90 oiling machine in 1962, Brunswick has been a leader and an innovator in automatic lane maintenance systems. And we've learned a lot along the way.

The Envoy, our newest lane machine, is a state-of-the-art system centered on your needs.

- Direct+ conditioning, with its direct-to-lane conditioner application, takes away the variation that comes with transfer system machines.
- Despite its sophistication, the six-button Graphical User Interface (GUI) makes the Envoy simple to program and easy to operate.
- Envoy's cleaning system, featuring a unique V-shaped squeegee, ensures your lanes are thoroughly clean so the shot is consistent.
- FlexPower gives you the option of running on AC or two different types of battery power, whatever your center needs.
- Since it only requires five minutes of daily maintenance and comes with a two-year warranty, the Envoy is easy to operate and maintain.

Today's center requires an intelligent machine that is so simple to operate that a new employee can run the lanes. Envoy has everything your center needs and the ability to create any shot your bowlers expect. It is truly a system centered on you.

Direct+ Conditioning Sets the Standard

When you talk about lane maintenance you're only as good as your conditioning system. With over 1,000 lane machines in use featuring Direct+ Conditioning, Brunswick delivers the industry leading performance bowlers have come to expect.

Direct+ applies conditioner simultaneously across the entire lane through 39 individually controlled Accu-ject injectors. Direct-to-lane application for each board provides unmatched consistency—no zigzags or multicomponent transfer systems to blur the results. With Direct+ Conditioning, you know the right amount of oil is on the lane exactly where you want it, regardless of lane topography.

FlexPower Is Ready When You Are

Simply put, Envoy delivers state-of-the-art power performance that can't be rivaled. With multiple battery and AC power options, this system provides primary and supplemental power you can always depend on – whenever you need it. Our AGM batteries cover a minimum of 32 lanes with a single charge, while the Lithium batteries can handle 60 lanes between charges.

EZ to Operate and Maintain

Unparalleled performance and flexibility make Envoy easy to understand and even easier to use. In fact, a new user can get up to speed in less than 30 minutes. Innovations like our EZ steer technology improve lane positioning and maneuverability with a new large front-wheel design.

Envoy can also be pre-programmed to apply different patterns on different sets of lanes for different leagues on different days. And daily maintenance is simple – just refill, clean, and wipe down the machine after use. User friendly with no wasted time and effort – that's Envoy.

Smart Enough To Be Simple

What good are great pattern options if you can't figure out how they work? The Envoy features a Graphical User Interface (GUI), making programming a breeze. Easy-to-read color displays are just as simple to use. Programming in units – the same measure used by the Computer Lane Monitor to assess pattern compliance – takes away the guesswork so adjustments can be made in seconds. The GUI can be removed for programming when and where it's convenient.

V-Scrub Gets It Clean

Cleaning is a major part of lane performance. With Envoy, machine speed is selected to optimize cleaning. Its four new cleaner nozzles are 50% larger to resist clogging. The unique V-shaped squeegee head guides waste for quick, efficient pickup. Even our absorbent wiper rotates and the squeegee blades flip to allow for multiple uses and reduced maintenance and operating costs.

LANE MACHINES

Choice of three cleaning speeds assures optimum performance while minimizing cleaner use.

Oil application is computer controlled by varying the injector pulse rate, not the speed of the machine. Machine speed is set to optimize cleaning and minimize time on the lane.

GUI can be easily removed from machine so you can program when and where it's convenient without moving the machine itself.

The universal battery charger operates on 100-250V AC input and comes with your choice of AGM or Lithium batteries. All machines are prewired for the optional onboard AC/DC power supply used for corded operation.

Center-mounted T-handle and EZ Steer provide enhanced control and easy maneuverability.

Four heavy-duty ball bearing transport casters are aligned for enhanced stability on ramps.



Wide-mouth cleaner and waste tanks have a capacity for 40+ lanes.

All cleaning components are found on the right side of the unit for easy identification and troubleshooting.

New, robust metal flow control valve for simple pressure adjustment.

OVERHEAD VIEW

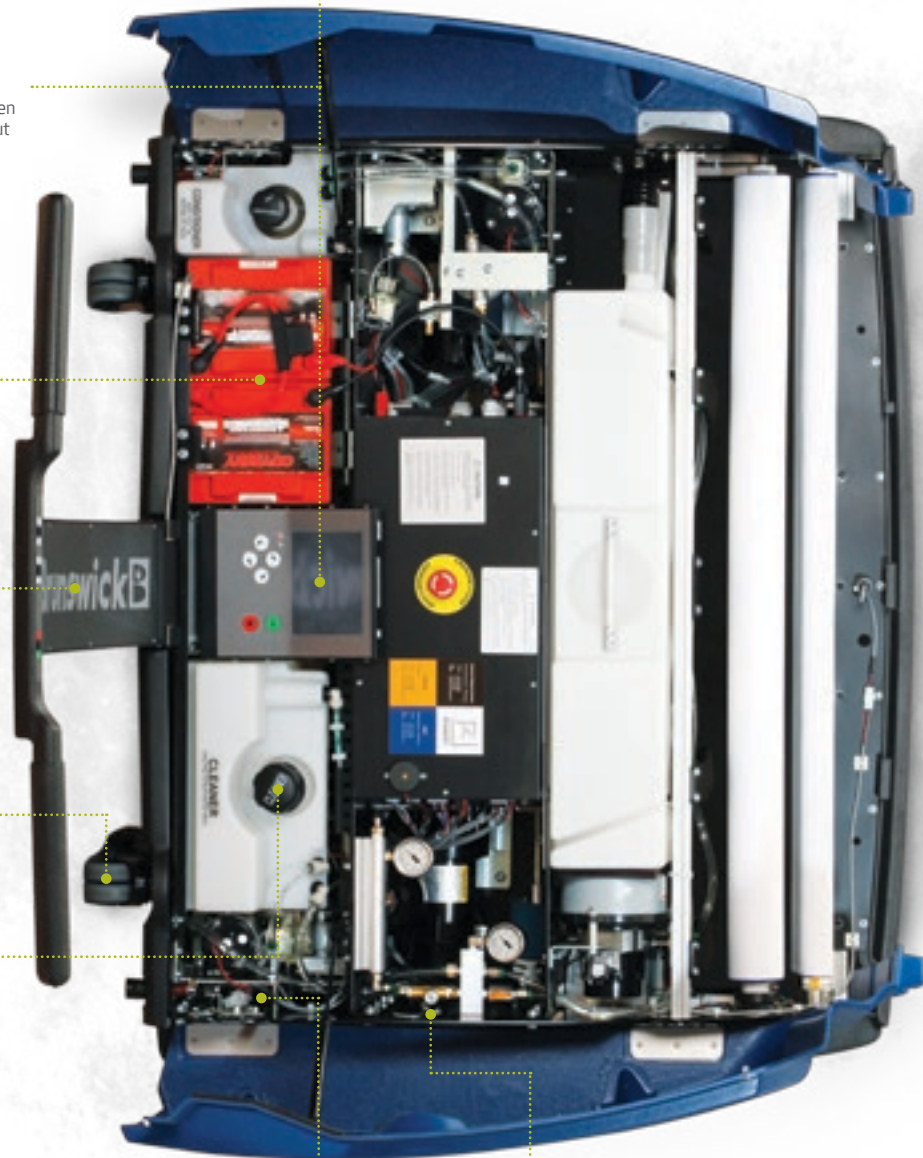



BOTTOM VIEW



Large 6" front wheels ease transition into gutter.

New adjustable cleaner nozzle brackets assure full lane coverage without messy gutter overspray.

V-shaped squeegee head guides waste to the waste tank.



Thirty-nine Accu-ject injectors leverage fuel-injector technology from Mercury Marine, a division of Brunswick.

Buffer brush finalizes taper for smoother transitions.

Black powder coating and zinc plating create a durable and corrosion resistant finish.

Automatic five-second spray pulse at the foul line helps clean heavy oil patterns.



Added ventilation in side frame helps cool the vacuum motor for longer life.

Duster cloth works dry to remove dirt before cleaner is applied, doubling the life of the cloth as compared to many competitive machines.



Direct+ applies conditioner directly to the lane surface, assuring oil is placed on the lane where required – without a multicomponent transfer system to blur the pattern.

LANE MACHINES



Authority22®

"OUR AUTHORITY22 LANE MACHINE HAS MADE MY BOWLERS HAPPY. AS A PBA® CHAMPION AND USBC® HALL OF FAME BOWLER, I KNOW THE IMPORTANCE OF A GOOD, CONSISTENT SHOT. AND SO DO MY BOWLERS.

THEIR SCORES ARE UP AND THAT MAKES THEM AND ME HAPPY!"

—PETE TOUNTAS · PROPRIETOR · GOLDEN PIN LANES · TUCSON · ARIZONA—





WHEN THE AUTHORITY22 WAS INTRODUCED IN 2005 IT MADE LANE MAINTENANCE SIMPLE AND INTUITIVE. TODAY IT'S STILL GOING STRONG.

AUTHORITY22® LANE MACHINE

The Authority22 is in use in over 1,000 centers worldwide. Released in 2005, the Authority22 set the new standard in lane maintenance. The Authority22 features Direct+ conditioning as well as many of the same features found in the Envoy. The corded design makes it a great machine for large centers as well as those that need state-of-the-art conditioning on a tighter budget.

Accurate and Consistent

The 39 Accu-ject injectors provide individual board-by-board application, assuring the shot on the lane matches the programmed pattern.

- Applying conditioner continuously and directly across the entire width of the lane, not in a moving "Z" pattern or onto a secondary application device, provides unmatched lane-to-lane consistency.
- The soft buffer brush finalizes the taper for smoother pattern transitions.
- Oil application is computer controlled by varying the injector pulse rate, not by the speed of the machine.
- The conditioner rail is heated so the oil is always at 80 °F before application. This assures the viscosity is the same, further ensuring consistent performance regardless of variations in your center's environment.

Simple to Program

The Authority22's Graphic User Interface (GUI) makes programming simple and intuitive. It can be pre-programmed to apply up to 10 different patterns on different sets of lanes for different leagues on different days.

- Lane conditioner patterns are programmed in units – the industry standard for monitoring pattern compliance – with zones and oil levels graphically displayed in color.
- The GUI is easily removed so you can program patterns anywhere without moving the machine from the storage or lane area.

Easy Maintenance

Just add conditioner and cleaner before use, then clean and wipe down the machine afterwards.

Fast and Efficient

The Authority22 does its job quickly. It takes only about 5 minutes to clean and condition each set of four lanes. It cleans, dries, and conditions the lane all on the forward pass. On the return pass, only the buffer brush operates to provide a final, visual smoothing of the pattern.

With its cast aluminum T-handle, large rear wheels, and ball bearing casters, the Authority22 is easy to maneuver.

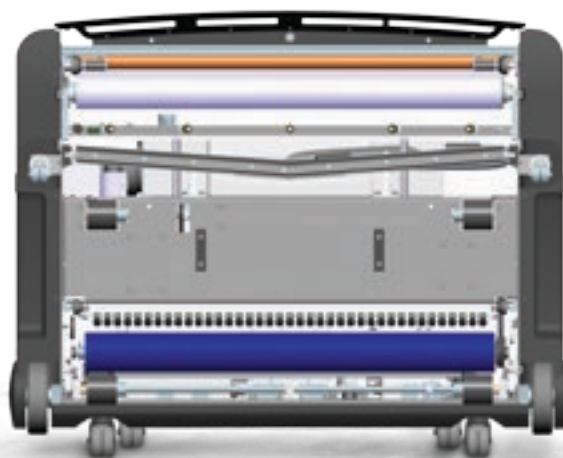

Direct-to-lane conditioner application means unmatched consistency lane to lane, day after day, week after week.

LANE MACHINES



Phoenix® LT4





THE PHOENIX LT4 IS AN AFFORDABLE LANE MACHINE DESIGNED SPECIFICALLY FOR CENTERS 16 LANES OR LESS.

PHOENIX® LT4 LANE MACHINE

New features have been added to enhance this easy to operate combination machine which cleans, oils and buffs in a single pass. The Phoenix LT4 is an efficient and affordable solution for your small center's lane maintenance needs.

- Clean and condition a 16 lane center without stopping to refill cleaner and conditioner tanks or emptying the waste tank
- Easy to use so that anyone can program or operate the Phoenix LT4 with little or no instruction
- Light and compact the Phoenix LT4 is easy and convenient to use and store
- New 4 pattern option provides both open and competitive bowling conditions



The touch-screen control module is easy to read and navigate.



BRUNSWICK LANE MACHINE COMPARISON CHART

Description	Envoy - Lithium/AC For larger centers. Appropriate for open, league, and tournament play.	Envoy - AGM/AC For small to medium size centers. Appropriate for open, league and tournament play.	Authority22 For large and small centers. Appropriate for open, league, and tournament play.	Phoenix LT4 For small centers. Appropriate for open play, and most leagues.
Conditioning System	Direct+ Conditioning with direct-to-lane application	Direct+ Conditioning with direct-to-lane application	Direct+ Conditioning with direct-to-lane application	6 pad Wick-type with multi-component transfer system
Pattern Capability	Nearly unlimited; 39 individually controlled injectors, 8 zones, applies up to 100 units on a single forward pass	Nearly unlimited; 39 individually controlled injectors, 8 zones, applies up to 100 units on a single forward pass	Nearly unlimited; 39 individually controlled injectors, 8 zones, applies up to 100 units on a single forward pass	4 cleaning and/or oiling program storage
Conditioner Tank Size	40 lanes	40 lanes	40 lanes	24 lanes
Waste/Cleaner Tank Size	40 lanes	40 lanes	40 lanes	16 lanes
Display/Interface	Graphic User Interface. 6.5" full color display, 6 buttons	Graphic User Interface. 6.5" full color display, 6 buttons	Graphic User Interface. 6.5" full color display, 6 buttons	Touch screen
Error Messages	Detailed log	Detailed log	Detailed log	No
Pattern Scheduler	By lane, time of day, and day	By lane, time of day, and day	By lane, time of day, and day	No
PC Software	Yes	Yes	Yes	No
Online Pattern Library	Yes	Yes	Yes	No
Power System	FlexPower - Lithium battery with charger or AC power cord	FlexPower - Two AGM batteries with charger or AC power cord	AC power cord	AC power cord
Lanes/Charge	60+ lanes on battery, Unlimited on AC	32+ lanes on battery, Unlimited on AC	Unlimited	Unlimited
Cleaning Speeds	3 - Selectable for each pattern	3 - Selectable for each pattern	2 - Selectable for each pattern	1
Cleaner application	4 nozzles	4 nozzles	5 nozzles	3 spray heads
Squeegee	V-shaped	V-shaped	V-shaped	Straight
Cloth	Dusting, dry	Dusting, dry	Dusting, dry	No
Tech Support	24/7/364 from Brunswick	24/7/364 from Brunswick	24/7/364 from Brunswick	24/7/364 from Brunswick
Warranty (summary)	2 years bumper to bumper excluding maintenance items; Battery prorated	2 years bumper to bumper excluding maintenance items; Battery prorated	1 year bumper to bumper excluding maintenance items	1 year excluding maintenance items

LANE MAINTENANCE

LANE CONDITIONERS

We understand the importance of having a conditioner that meets your center's unique lane conditions. Whether you have a 60-lane synthetic house focused on league play or a 6-lane wood lane center for recreational play, we have the right conditioner for you. All Brunswick conditioners are formulated to provide key performance characteristics including: stability, durability, minimal transition, and consistency. They are 100% silicone free to allow for easier cleaning.



LOGIC™
62-860162-005

Introduced in 2010, Logic blends top-grade oils with an enhanced additive package. The result is a low-lubricity conditioner with great durability and ball motion on harder, less aggressive surfaces.



DEFYv30™
62-860166-001

DEFY™
62-860164-001



New DEFYv30 adds a higher viscosity version of DEFY into Brunswick's performance conditioner line. Developed with the same specialty blend of top grade oils and unique additives used to create DEFY, both conditioners generate unparalleled performance compared to lane conditioners in the market today. The enhanced flow-back characteristic reduces the impact of ball tracks through the heads while minimizing the movement of conditioner down lane to keep the shot more consistent.



AUTHORITY22® W22™
62-860205-005

Authority22 W22's enhanced additive package combined with a special blend of oil creates an easy-to-use product. This premium-performance lane conditioner features reduced carry down and can be easily removed with normal daily cleaning.



CONNECT®
62-860160-005

Popular since its 2009 introduction, Connect combines cutting-edge technology with real-world expectations. Connect uses top-grade oils with a unique additive package to assure great durability and ball reaction. Connect lane conditioner allows you to run longer patterns without the risk of losing the outside boards.



ABSOLUTE CONTROL®
62-860143-005

CONTROL®
62-860046-005

Absolute Control combines the formulas and ingredients from Brunswick's highly successful Absolute HV and Control lane conditioners for great durability, flexibility, and easy cleaning. Control and Control LV lane conditioners offer long-lasting patterns, reduced carry down, and better ball reaction. Control LV's reduced viscosity improves wick flow in wick/pad lane machines.



COMMAND®
62-860022-005

Command is Throbot™-tested and proven in leagues worldwide. It's formulated to stand up to today's high-performance bowling balls and powerful bowlers.



LANE CONDITIONER RECOMMENDATIONS

CONDITIONERS FOR USE IN PUMP WITH TRANSFER SYSTEM AND 39 INJECTOR WITH DIRECT-TO-LANE MACHINES

LANE TYPE	SURFACE CONDITION	RECOMMENDED CONDITIONERS
Wood with Barricade/Guardian	All	Absolute Control, Authority22 W22, Command, DEFY, and DEFYv30
Wood with Water-base Finish	All	Absolute Control, Authority22 W22, Command, Control, DEFY, and DEFYv30
Wood with Moisture Cure Urethane Finish or 100% Solids Epoxy Finish	All	Absolute Control, Authority22 W22, Command, Control, DEFY, and DEFYv30
Wood with Lane Shield	All	Authority22 W22, Control, DEFY, and DEFYv30
AMF HPL 9000, 1/2" DBA IQ, 7/16" Anvilane™	All	Authority22 W22, Connect, Control, DEFY, and DEFYv30
Newer Brunswick Pro Lane™,* 3/8" Anvilane, AMF SPL, Murrey Pathfinder II, System 300, Mendes	All	Authority22 W22, Connect, Control, DEFY, DEFYv30, and Logic
Early Brunswick Pro Lane**	Good - Excellent	Connect, Control, DEFY, DEFYv30, and Logic
Early Brunswick Pro Lane**	Fair - Poor	Connect, Control, DEFY, DEFYv30, and Logic

CONDITIONERS FOR USE IN WICK/PAD WITH TRANSFER SYSTEM MACHINES

LANE TYPE	SURFACE CONDITION	RECOMMENDED CONDITIONERS
Wood with Barricade/Guardian	All	Absolute Control, Authority22 W22, DEFY, and DEFYv30
Wood with Water-base Finish	All	Absolute Control, Authority22 W22, Command, DEFY, and DEFYv30
Wood with Moisture Cure Urethane Finish or 100% Solids Epoxy Finish	All	Authority22 W22, Command, DEFY, and DEFYv30
Wood with Lane Shield	All	Authority22 W22, Control LV, DEFY, and DEFYv30
AMF HPL 9000, 1/2" DBA IQ, 7/16" Anvilane	All	Absolute Control, Authority22 W22, Command, Control LV, DEFY, and DEFYv30
Newer Brunswick Pro Lane,* 3/8" Anvilane, AMF SPL, Murrey Pathfinder II, System 300, Mendes	All	Absolute Control, Authority22 W22, Control LV, DEFY, and DEFYv30
Early Brunswick Pro Lane**	All	Absolute Control, Authority22 W22, DEFY, and DEFYv30

* Installed 2005 or later, typically with textured approaches

** Installed through 2005, typically with non-textured approaches

LANE MAINTENANCE

LANE CONDITIONERS – THROBOT™ TEST RESULTS

Throbot, Brunswick's state-of-the-art ball-throwing robot, was designed and fabricated in the late 1990s for bowling ball development. Since 2000, we've also used this testing technology to develop high-performance lane conditioners and cleaners. Unlike human bowlers, Throbot can perfectly duplicate the throw of a ball down the lane time after time. That means any variation in the ball's path and speed can be attributed entirely to the different conditioner formulas. Brunswick has used this data to fine-tune the formulations of our products in order to produce more desirable performance characteristics. Throbot testing provides objective, comparable data on conditioner performance.

- Oil Predictability is the measurement of the durability of the conditioner. It reflects how long the conditioner holds up in the oil pattern before it begins to deplete and change the performance characteristic of the lane. More durable conditioners will have higher ratings.
- Backend Predictability reflects the stability of the entry angle on the backend as a result of carry down beyond the end of the oil pattern. On conditioners with higher ratings, balls will respond less to carry down and have more consistent backend reactions.
- Speed Loss quantifies the resistance against the ball as it travels through the oil pattern. Conditioners with lower values match up better with more aggressive lane surfaces, while those with higher values can be a better match on lower friction lane surfaces.

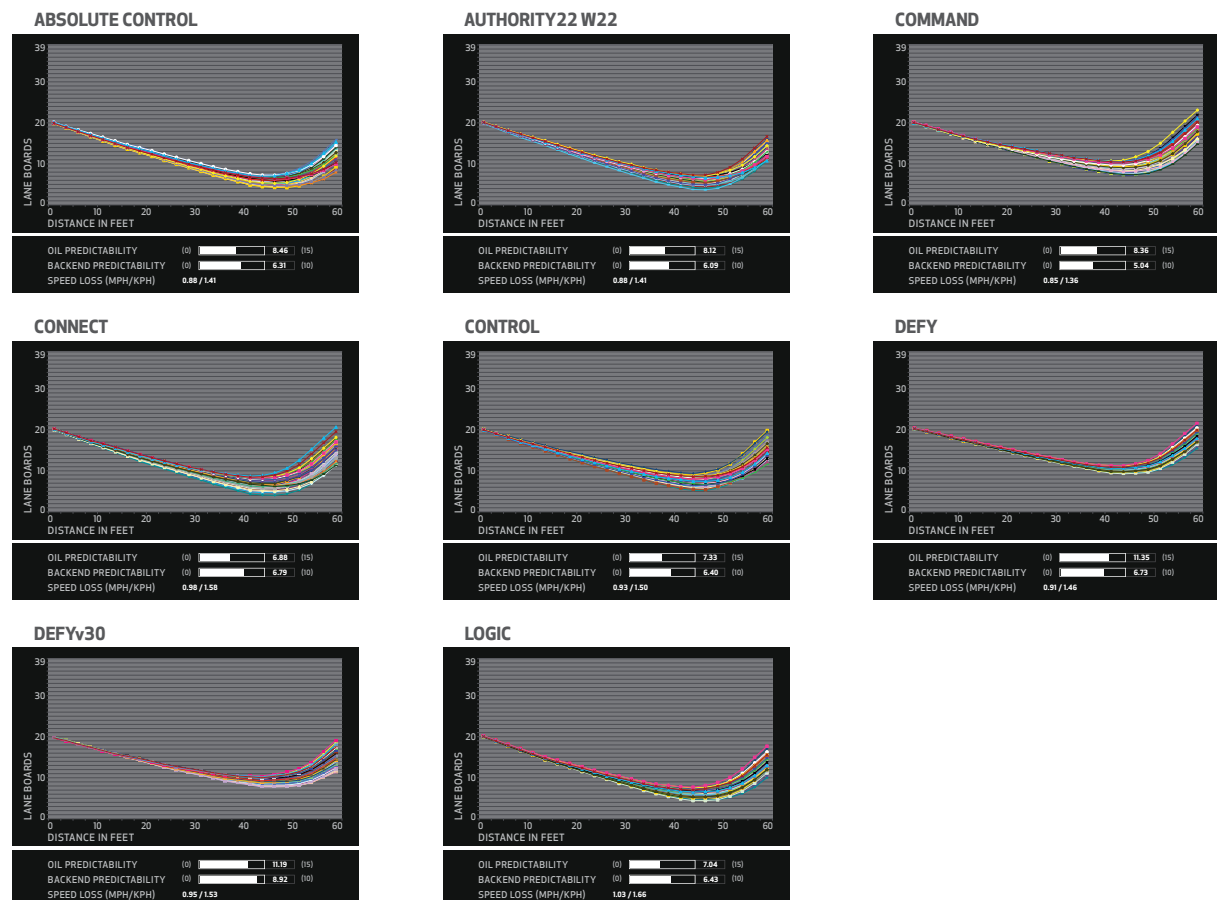



LANE CLEANERS

Brunswick BGreen lane cleaners – and Universal Pin Cleaner – are readily biodegradable and allow you to clean your lanes with environmentally friendly formulas. BGreen cleaners meet the rigid requirements for detergent biodegradability defined by the European Parliament.

JUDGE®

62-860066-005

Formulated with an enhanced combination of additives, Judge cleans synthetic and mineral-oil-based conditioners. Judge is a nonhazardous cleaner that can be used with all pump or injector lane machines.



INVINCIBLE®

62-860055-005

Still a Brunswick top seller, Invincible cleans even the toughest lane conditioners. Its formulation is fast acting for today's newer lane machines.



MAX10

62-860239-025
(2.5-gallon bottle)

MAX20™

62-860239-000
(10 one-pint bottles)

Brunswick's newest concentrated cleaners, MAX10 and MAX20, clean even tough conditioners in a single pass. Nonhazardous BGreen™ products, their smaller packaging makes them easy to store and handle. Both are liquid concentrates for easy mixing.



AUTHORITY22®

62-860206-005

Authority22's cleaner formulation reflects the latest advancements in surfactant technology. It provides fast and superior cleaning power to remove even the toughest conditioners from your lanes.

LANE CLOTH



8460QC

61-860290-000
(4 Rolls/carton)

8460QC uses the same proven heavy-duty material found in the 8460XL blue cloth but features a quick-change plastic core. This new design will save you time and scrub your lanes clean.



8460XL LANE CLEANING CLOTH

61-860250-000
(4 Rolls/carton)

8460XL virtually "scrubs" cleaning solution onto the lane with its special fiber cloth. Use with wick/pad and pump lane machines.



GOLD EDGE LANE CLEANING/DUSTER CLOTH

61-860252-000
(4 Rolls per carton)

Gold Edge Cloth is composed of a special mixture of fibers to maximize "scrubbing action" and edge out the competition.



AUTHORITY22/ENVOY DUSTER CLOTH

62-860207-000
(4 Rolls/carton)

Authority22/Envoy Duster Cloth cleans the lane before the cleaner is applied. The process uses less cloth and helps the cleaner work directly on the conditioner, not the surface dirt.



RED EDGE® LINO-DUSTER CLOTH

61-860168-000
(3 Rolls per carton)

52-860078-000
(4 Rolls per carton)
Red Edge Lino-Duster Cloth contains strong, long fibers that trap and hold dirt improving cleaning performance.

LANE MAINTENANCE

APPROACH SUPPLIES

Keeping the approach clean is essential to creating an optimum and equitable scoring environment for your bowlers. Brunswick is a leader in developing approach supplies that provide better slide characteristics. From approach cleaners and powders to mops, we have the products your center needs to keep approaches in top bowling condition.

APPROACH MOP - 62-860095-000

IPA 99 SYNTHETIC APPROACH CLEANER - 61-860254-000

APPROACH DRY SLIDE - 62-860210-600





MAINTENANCE SUPPLIES

Beyond pinsetters and lanes, bowling centers have many maintenance needs. Brunswick offers a full line of cleaning and maintenance products to keep your center running smoothly. From spot cleaner to pin deck treatments, Brunswick has all the supplies you need.

LIQUID FRICTION – 62-860138-000

SANI-SPRAY SHOE SANITIZER – 61-860062-000

AUTOMATIC PINSETTER CLEANER – 62-860083-005



COMPUTER LANE MONITOR SYSTEM

Verify the lane conditions are USBC® compliant with the Computer Lane Monitor System. Periodically monitoring patterns will keep bowlers satisfied by ensuring the lane conditions are the same from lane to lane and week to week. Not only measure newly conditioned lanes but check changes in lane conditions, such as oil depletion and carry-down.

61-860226-600



PINSETTER PARTS

GENUINE BRUNSWICK PARTS

For more than 50 years, Brunswick pinsetters have served as the backbone for bowling centers worldwide. As the original manufacturer, only Brunswick can provide parts specially designed for your pinsetters. That means dependability for your center and quick and easy repairs for your mechanic. All Genuine Brunswick Parts are tested and validated to stringent Brunswick specifications, ensuring your pinsetters perform at their very best. In recent years, Brunswick has put a renewed emphasis on developing and launching new pinsetter parts. Many of these parts have been inspired by pinsetter mechanics across the world. We are pleased to continue to provide innovative pinsetter solutions for our customers.

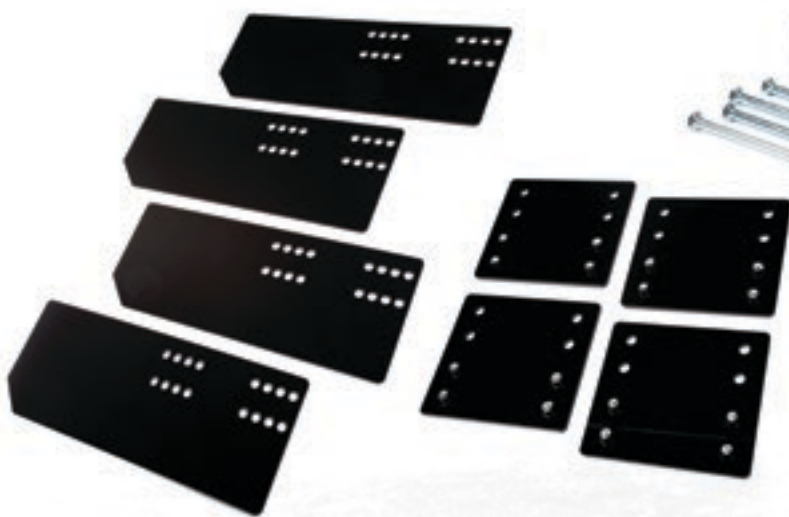

PIN FEED EXTENDER KIT
47-862507-000

- Improves elevator pin loading efficiency
- Decreases distributor time outs by up to 90%
- Kit is packaged for lane pair
- One drill template per center required - 47-862508-000 (not included)



**ADVANCED PERFORMANCE
ADJUSTABLE "Y" SWITCH**
12-862033-000

- Reduces ball jams
- Easy to adjust from back of pinsetter
- Complete with hardware and instructions



**ADVANCED PERFORMANCE
URETHANE FOAM BALL LIFT TIRE**
90-520060-600

- Specially formulated foam material to optimize ball lift performance
- Excellent durability
- Hardware not included



FRAMEWORX® CONSOLE FLASH DRIVE KIT
57-863397-400

- Solid state hard drive replacement kit
- No moving parts
- Pre-programmed with Frameworx software 6.3
- Complete with cable, hardware, and instructions

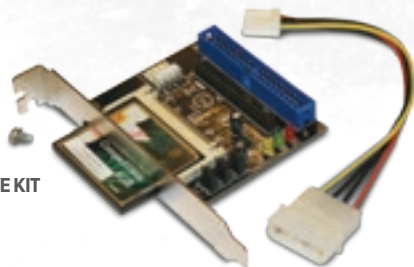

**CORK/RUBBER BALL WHEEL
TRACTION MATERIAL**
12-860336-000

- Premium 3M® brand adhesive for instant bond
- Special blend of cork and rubber
- Reduces ball calls
- 23.5' x 1.5" roll





OEM PLUS™ URETHANE DECK CHUTE

12-200808-502 - #1
12-200837-500 - #5
12-200808-503 - #7 & #10
12-200900-500 - MULTI

- Arguably the most functional urethane deck chute on the market today
- Injection molded using premium Bayer® urethane
- Very low coefficient of friction between pin and deck chute for jam free pin transfer
- Two-year warranty



UNIVERSAL PIN STATION

47-094792-009 - (2, 3, 4, 8, 9)
47-094793-009 - (1, 5, 6)
47-094794-009 - (7, 10)

- Original OEM pin station
- Improved pin release lever attachment pivot

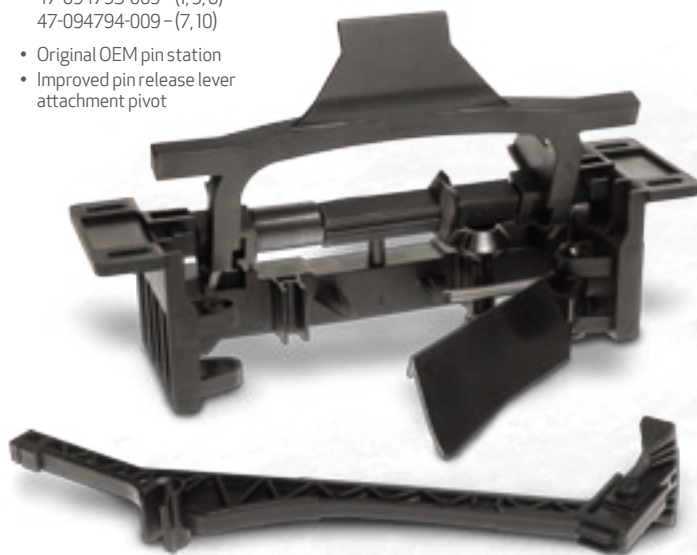

UNIVERSAL RELEASE LEVER

47-095154-009 - (complete)
47-094782-003 - (button only)

- Wider, replaceable button
- Use on all universal pin stations

ADVANCED PERFORMANCE IMPACT STRIPS

47-026102-009

- Lasts three to five times longer than the original impact strips
- Replace less frequently, saving time and money
- Made from ultra-high molecular weight polyethylene
- Comes two per package



CENTER OPS PRODUCTS

PINS

All Brunswick pins feature a durable Surlyn® coating. Surlyn is a high-performance resin known for its outstanding resilience and impact toughness. Surlyn is the same cover material used for high-performance quality golf balls. Our Score King and Max pins feature UV brightener for ultra-white glow under standard lighting; brighter under UV conditions. Pins with glow graphics have an enhanced logo for extra glow under UV conditions.

Multilayer topcoat system keeps pins white and glowing brightly

Surlyn cover allows for a larger wood core to ensure maximum strength

Made of the finest northern hard rock maple for maximum durability and pin action

Score King pins feature a heavy-duty, locked-in black nylon base that looks great

Score King and Max pins are USBC approved

All Brunswick pins are made in the USA

Choose stripes or crown neck graphics

Coated Surlyn cover cleans easily and stays whiter longer

Max pins have a neutral locked-in base that stays in place

SCORE KING® PINS
 63-861179-167 – Crowns
 63-861180-167 – Crowns – Glow Graphics
 63-861181-167 – Stripes
 63-861182-167 – Stripes – Glow Graphics

MAX PINS
 63-861167-167 Crowns
 63-861165-167 Crowns – Glow Graphics
 63-861168-167 Stripes
 63-861166-167 Stripes – Glow Graphics

HAPPY BIRTHDAY PIN

62-861092-167

Help your bowlers celebrate their birthdays with this special-occasion pin featuring the crown graphic as well as a "Happy Birthday" message. The Happy Birthday Pin is a Surlyn-coated maple wood pin that can be used for signatures, too. Available in sets of ten.

TROPHY PIN

63-861157-167 – Set
 63-861157-000 – Single

Perfect for special occasions to help your bowlers remember a significant score or event, our Trophy Pin is made of maple wood covered in a clear topcoat. It can be used as a signature pin for birthday parties or other special events. Available in sets of ten or individually.



MAX COLORED PINS

- 63-861137-167 – Green
- 63-861139-167 – Orange
- 63-861138-167 – Yellow
- 63-861161-167 – Magenta

Let the good times roll with these fun and colorful Max pins. Change out the front pin or the whole set for a new twist on the game or to award prizes. Available in four vibrant, solid colors. Available in single-color sets of ten.

UNIVERSAL PIN CLEANER

63-860354-005

Keep pins looking bright and new with this advanced performance pin cleaner.



RENTAL SHOES



PREMIUM RENTAL SHOES

58-109114-XXX – Lace
 58-109116-XXX – Hook-N-Loop

If only everything returned its investment as fast and as many times over as Brunswick Premium Rental Shoes. Featuring genuine full-grain leather uppers, foam-padded sock liners, channel stitching, and rubber heels, these shoes are built to last game after game.



HYBRID RENTAL SHOES

58-109305-XXX – Adult Lace
 58-109306-XXX – Adult Hook-N-Loop
 58-109304-XXX – Youth Hook-N-Loop

A new contemporary look will enhance the image of your center. Full grain leather soles with recessed stitching, double stitched synthetic uppers, padded insoles and air grommets make this multi-featured shoe a great choice to enhance the bowling experience for your customers. Lace pairs come with extra laces.



VALUE SPORT RENTAL SHOES

58-109303-XXX – Adult
 58-109302-XXX – Youth

With sporty styling and great performance these shoes are perfect for boutiques, family entertainment centers, and traditional centers. They have the features you need at a very attractive price. These value sport rental shoes are truly an exceptional value.



YOUTH RENTAL SHOES

58-109115-XXX

The hook-n-loop closure makes these the perfect choice for younger bowlers. The full grain leather sole and uppers provide the quality and durability required by your bowling center.

CENTER OPS PRODUCTS

MYBALL™ HOUSE BALLS

Live up your center with Brunswick house balls. These bright, glow-in-the-dark bowling balls add color and excitement to any bowling environment. They are a great value and carry a 2-year warranty; 1-year for 6-pound balls. Both MyBall and Billiards styles available from 6 to 15 pound.

60-105544-9XX – Undrilled

60-105544-XXX – Drilled

60-105507-9XX – Billiards Undrilled

60-105507-XXX – Billiards Drilled

New-formulation
Brunswick MyBall house
balls radiate with light for
the ultimate experience!

Strong enough to withstand
young or unskilled bowlers

Available in seven drilling
sizes as part of the MyBall
System



LIME GREEN PEARL



FUCHSIA PEARL



SKY BLUE PEARL



VIOLET PEARL



ORANGE PEARL



PURPLE PEARL



RED PEARL



YELLOW PEARL



KELLY GREEN PEARL



DARK BLUE PEARL



STRIPED BILLIARD



SOLID BILLIARD



MYBALL™ SYSTEM

Make selecting a good-fitting house ball easier for your customers with the MyBall System from Brunswick. Our color-coded system and MyFit sizing ball allow customers to easily identify which ball will work best for them, improving bowler satisfaction.

R8-010059-000

Easy identification of hole size and weight. Speeds up the selection process, equaling more time for bowling.

With the MyFit sizing ball, customers select from seven hole drilling sizes (XXS-XXL), then look for their preferred ball weight (6-15 pounds) with the selected hole size.

The MyBall System incorporates the MyFit sizing ball with counter display and Cosmic Premium Urethane House Balls.



BALL CARTS & BALL RAMP

NEW

These durable and attractive ball carts enable you to easily transport house balls across the center as needed. The ball ramp enhances the bowling experience for younger bowlers, or those with special needs, making bowling more fun and bringing them back again and again.



BALL CART - TWO TIER
62-860311-000



BALL CART - THREE TIER
62-860312-000



BALL RAMP
62-860310-000



525 West Laketon Avenue
Muskegon, MI 49441-2601 USA
1-800-Yes-Bowl (Options 2,2,*)
1-231-725-4966 (Options 2,2,*)
inquiries@brunbowl.com
www.brunswickbowling.com

Go to www.brunswickbowling.com/contact/sale-rep/ to find a local Brunswick Sales Representative

Surlyn is a registered trademark of E.I. du Pont de Nemours and Company. USBC is a registered trademark of United States Bowling Congress, Inc. PBA, Professional Bowlers Association and PBA Logo are registered service marks of Professional Bowlers Association, LLC. 3M is a trademark of the Minnesota Mining & Manufacturing Company. Bayer is a registered trademark of Bayer Aktiengesellschaft. All other trademarks belong to Brunswick Bowling Products, Inc.

Brunswick is committed to continuous improvement. As a result, all specifications and options are subject to change without notice. Not for reproduction without the express written consent of Brunswick Bowling Products, Inc.

©2015 Brunswick Bowling Products, Inc. Printed in the USA. Item #10-095200-006 • Form #0615-53

2015-2016 BROCHURE